

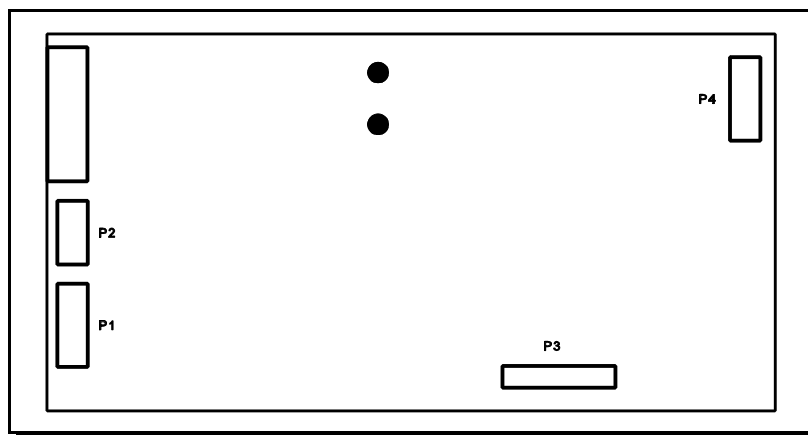

FW-DACT

Digital Communicator

INSTALLATION and OPERATION MANUAL



L NOTICE

All information, documentation, and specifications contained in this manual are subject to change without prior notice by the manufacturer.

TABLE of CONTENTS

INTRODUCTION - MODELS & FEATURES Page 1

 Notice for all FW-DACT, Sold in Canada Page 2

 Notice for all FW-DACT, Sold in the U.S.A. Page 2

CONNECTIONS AND SETTINGS Page 3

FIELD WIRING Page 4

SYSTEM CONFIGURATION & OPERATION Page 5

REPORTING FORMATS Page 7

COMPATIBLE FIRE ALARM CONTROL PANELS Page 8

COMPATIBLE RECEIVERS Page 8

SPECIFICATIONS Page 9

BATTERY CALCULATIONS Page 9

WARRANTY Page 10

INTRODUCTION - MODELS & FEATURES

FW-DACT: A single board Digital Communicator that can connect via Contact Closure Inputs on a single ribbon cable to a NAPCO Fire Alarm Control Panel (FACP) such as the FW-C2Z, FW-C4Z or FW-C4EZ. It can transmit Common Alarm, Common Supervisory, and Common Trouble information on two telephone lines.

- T Communicates to a FACP via **Contact Closure Inputs** (FW-DACT).
- T User Configurable with **FW-PCTOOL Configuration Tool**. This includes a 4-Line LCD Display and Keypad in a rugged metal enclosure, with a ribbon cable to connect to the Communicator.
- T Communicates to a **Central Monitoring Station** using **Ademco Contact ID** or **SIA DCS** Protocols.
- T The **FW-DACT** can transmit Common Alarm, Common Supervisory and Common Trouble information on two telephone lines.

The **DACT** continuously supervises the state of each of two connected Telco Lines (at approximately 1 minute intervals) by both a Line-DC level measurement, and by checking for a Dial-Tone. If either fails, a Line #1 or Line #2 Trouble event will be reported. Once a Line has been restored, a Line Trouble Restored event will be reported. The product will *always* report events sorted in the order in which they are received / recognized. The products are capable of reporting multiple events to a single Account number, within a single call session. Up to 4 retries, for a single message not yet reported, will be made within a single call-attempt. A failure to communicate to either or both Accounts will generate a corresponding event which will be queued for reporting.

Notice for all FW-DACT Sold in Canada:

NAPCO's **FW-DACT Digital Communicator** described in this manual are listed by Underwriters Laboratories Canada (ULC) for use in slave application in conjunction with a Listed Fire Alarm Control Panel under Standard ULC-S527 (Standard for Control Units for Fire Alarm Systems) and ULC/ORD-C693-1994 (Central Station Fire Protective Signalling Systems and Services). These Communicators should be installed in accordance with this manual; the Canadian / Provincial / Local Electrical Code; and/or the local Authority Having Jurisdiction (AHJ).

Industry Canada Notice:

The Industry Canada label identifies certified equipment. This certification means that the equipment meets certain telecommunications network protective, operational and safety requirements. Industry Canada does not guarantee the equipment will operate to the user's satisfaction. Before installing this equipment, users should ensure that it is permissible to be connected to the facilities of the local telecommunication company. The equipment must also be installed using an acceptable method of connection. The customer should be aware that compliance with the above conditions may not prevent degradations of service in some situations.

Repairs to certified equipment should be made by an authorized Canadian maintenance facility designated by the supplier. Any repair or alteration made by the user to this equipment, or equipment malfunction, may give the telecommunications company cause to request the user to disconnect the equipment. Users should ensure for their own protection that the **Earth Ground** connections of the power utility, telephone lines and internal metallic water pipe system, if present, are connected together. This is necessary both for proper operation and for protection.

CAUTION: *Users should not attempt to make such connections themselves, but should contact the appropriate electric inspection authority, or electrician, as appropriate.*

NOTICE: *The Ringer Equivalence Number (REN) assigned to each terminal device provides an indication of the maximum number of terminals allowed to be connected to a telephone interface. The termination on an interface may consist of any combination of devices subject only to the requirement that the sum of the Ringer Equivalence Numbers of all the devices does not exceed 5.*

Notice for all FW-DACT Sold in the U.S.A.:

NAPCO's **FW-DACT Digital Communicator** described in this manual are listed by Underwriters Laboratories Inc. (ULI) for use in slave application in conjunction with a Listed Fire Alarm Control Panel under Standard 864 (Control Units for Fire Protective Signalling Systems) and applicable section of Standard 1635 (Digital Alarm Communicator System Units). These Communicators comply with the National Fire Protection Association (NFPA) performance requirements for DACT's and should be installed in accordance with NFPA 72 Chapter 4 (Supervising Station Fire Alarm System). These Communicators should be installed in accordance with this manual; the National Electrical Code (NFPA 70); and/or the local Authority Having Jurisdiction (AHJ).

FCC Notice:

Type of Service: The **Communicator** is designed to be used on standard device telephone lines. It connects to the telephone line by means of a standard jack called the USOC RJ-11C (or USOC FJ45S). Connection to telephone company provided coin service (central office implemented systems) is prohibited. Connection to party lines service is subject to state tariffs.

Telephone Company Procedures: The goal of the telephone company is to provide you with the best service it can. In order to do this, it may occasionally be necessary for them to make changes in their equipment, operations or procedures. If these changes might affect your service or the operation of your equipment, the telephone company will give you notice, in writing, to allow you to make any changes necessary to maintain uninterrupted service.

In certain circumstances, it may be necessary for the telephone company to request information from you concerning the equipment which you have connected to your telephone line. Upon request of the telephone company, provide the FCC registration number and the ringer equivalence number (REN); both of these items are listed on the equipment label. The sum of all of the REN's on your telephone lines should be less than five in order to assure proper service from the telephone company. In some cases, a sum of five may not be useable on a given line.

If Problems Arise: If any of your telephone equipment is not operating properly, you should immediately remove it from your telephone line, as it may cause harm to the telephone network. If the telephone company notes a problem, they may temporarily discontinue service. When practical, they will notify you in advance of this disconnection. If advance notice is not feasible, you will be notified as soon as possible. When you are notified, you will be given the opportunity to correct the problem and informed of your right to file a complaint with the FCC. Contact your telephone company if you have any questions about your

phone line. In the event repairs are ever needed on the Communicator, they should be performed by NAPCO Security Systems, Inc. or an authorized representative of NAPCO Security Systems , Inc.. For information contact NAPCO Security Systems, Inc. at the address and phone numbers shown on the last page of this document.

CONNECTIONS AND SETTINGS

FW-DACT MAIN BOARD:

There are no user configured jumpers on this Communicator.

- P1** Ribbon Cable for connecting to NAPCO Fire Alarm Control Panel (FACP).
- P2** RS-485 Connection for future expansion.
- P4** Connector for FW-PCTOOL Configuration Module.
- I2** Status Indicator LED for Telco Line #1; Red when the line is in use, Amber when there is a line fault.
- I1** Status Indicator LED for Telco Line #2; Red when the line is in use, Amber when there is a line fault.

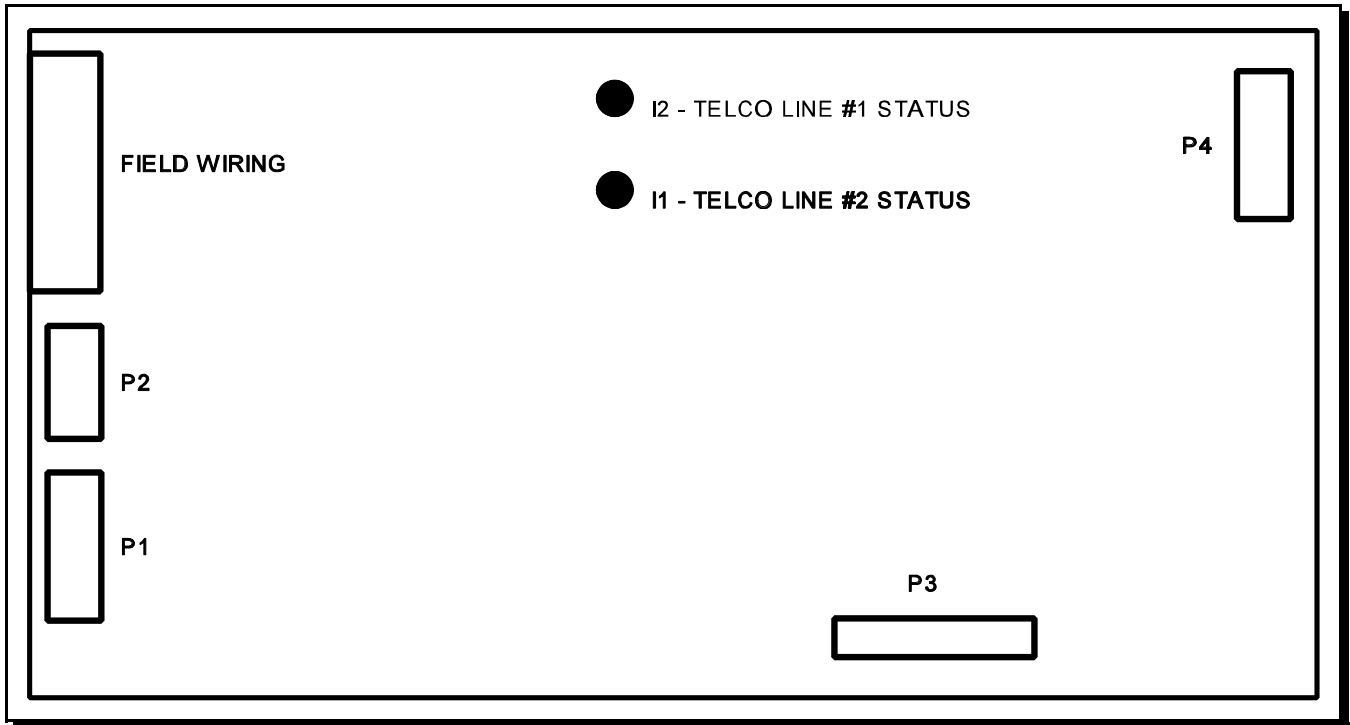

FIELD WIRING

FW-DACT MAIN BOARD TERMINAL CONNECTIONS:

Wire the two telephone lines devices to terminals as shown.

Line 1 Input (Tip/Ring): To the first Telephone Line via the required RJ31X Connector.

Line 1 Output (Tip/Ring): To an optional Premise Telephone on the first Telephone Line via the required RJ31X Connector.

Line 2 Input (Tip/Ring): To the second Telephone Line via the required RJ31X Connector.

Line 3 Output (Tip/Ring): To an optional Premise Telephone on the second Telephone Line via the required RJ31X Connector.

Note that most AHJ's do not allow the connection of Premise Telephones. See wiring tables and specifications for more information.

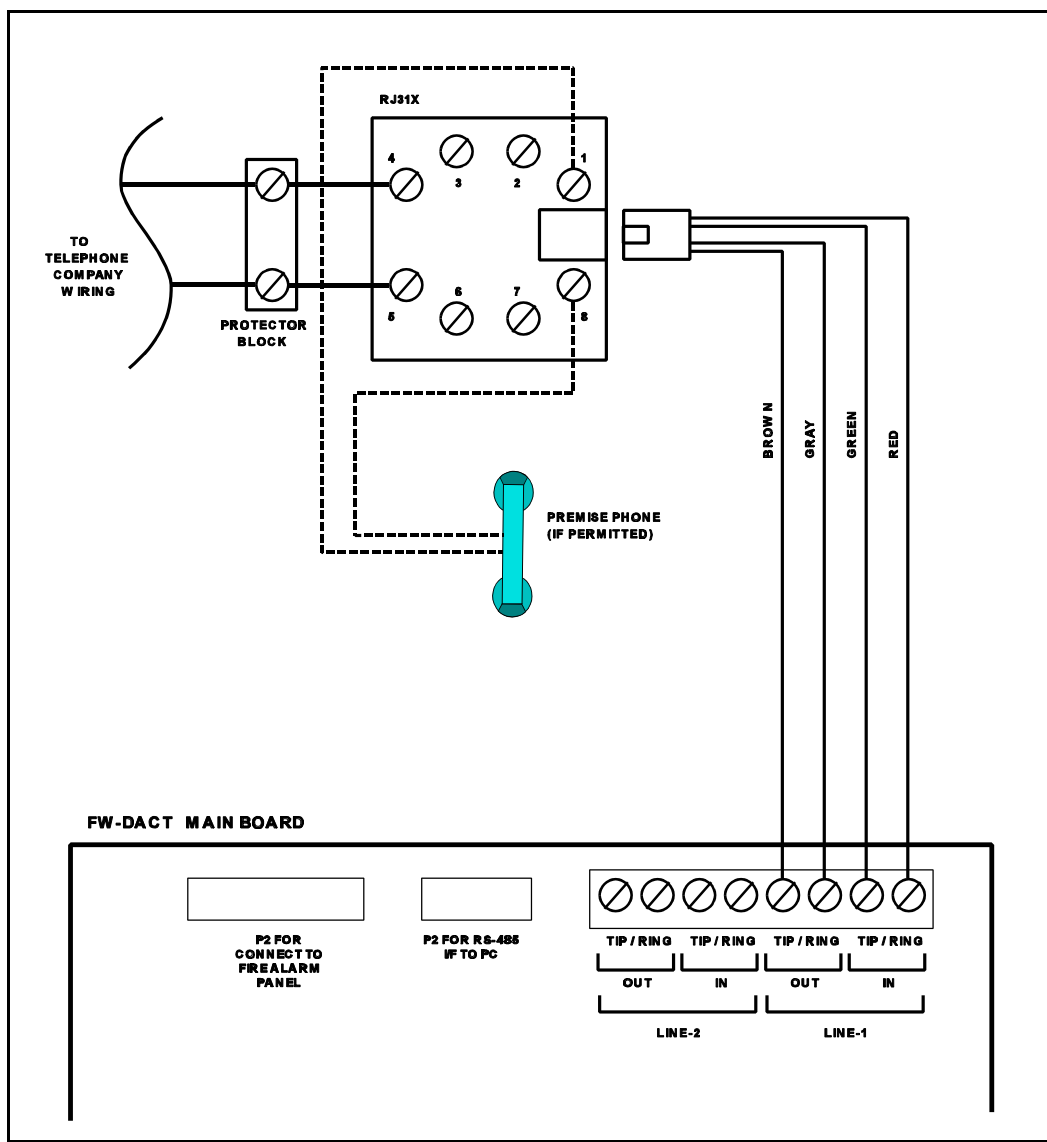

SYSTEM CONFIGURATION & OPERATION

The NAPCO Digital Communicator is configured by connecting the **FW-PCTOOL Configuration Tool** to P4 of the FW-DACT Main Board. Once connected, if no text appears immediately on the LCD screen, hit any key on the numeric keypad.

The DACT supports three levels of restricted access to the **Configuration Mode** which allows for parameter configuration and control of operation. Each level is associated with a separate **Passcode** (up to 8-digit numeric code) and may be individually modified. Once a user gains access to the Configuration Mode, they are presented with a menu of selections according to the level of access granted. The **factory default** Passcodes are:

Level I - OPERATOR "11111111"
Level II - INSTALLER "22222222"

A **Restore-to-Factory-Defaults** can be initiated from the FW-PCTOOL *without having to first access program mode*, by using the special Passcode ...

Restore-to-Factory-Defaults "12345678"

Items accessible to Level(s) I and II

<u>ITEM Number</u>	<u>Access Level</u>	<u>Menu Category</u>	<u>Menu Label</u>	<u>Description</u>
00	I, II	Access Control	Logout of DACT	Exit from PROGRAM mode on LCD/Keypad.
01	I, II	Access Control	About DACT	Display copyright (company and date) and firmware version information on LCD.
02	I, II	Access Control	Change Passcode	Support modification to specific passcode associated with individual level.
10	I, II	Event Logging	Flush all events	Terminate any in-progress event reporting. Remove "report pending" trigger (i.e. cancel attempts to report queued events) and Force event queue (FIFO) to empty state (i.e. erase any queued event history).
11	I, II	Event Logging	Send Test-Report	Immediately initiate test-report generated to Account #1.
12	I, II	Event Logging	Abort-Reporting	Terminate any in-progress event reporting. Remove "report pending" trigger (i.e. cancel attempts to report queued events). NOTE: Unreported events are still resident within FIFO. Any future events logged will restart attempts at reporting ALL queued (unreported) event items. This action will also add a "Line (x) Trouble" event to the event queue.
13	I, II	Event Logging	AC-Power Loss (delay)	Specify an (optional) delay time (in hours), from 00 (no delay) to 20 (maximum delay). A report of the "AC-Power Loss" event will be delayed by this value, and then only sent after the period has expired with the signal still present. A "restoral" event of this signal will be reported immediately, but only if a prior "off-normal" event was successfully reported earlier.
20	I, II	Real Time Clock Parameters	Set System DATE	Assign local DATE (dd/mm/yy) to DACT Real-Time-Clock device. The Year field will be presented in 4-digit format on LCD status line, with automatic 20/21 century adjustment for Y2K compliance.
21	I, II	Real Time Clock Parameters	Set System TIME	Assign local TIME (ss/mm/hh) to DACT Real-Time-Clock device. The Hour field will be presented in 24-hour (military) format on LCD status line.

22	I, II	Real Time Clock Parameters	Auto-Report Time	Assign time (mm/hh) for DACT to perform periodic (24 hr intervals) Test-report generation to monitoring station .
----	-------	----------------------------------	------------------	---

Items accessible to Level III only

<u>ITEM Number</u>	<u>Access Level</u>	<u>Menu Category</u>	<u>Menu Label</u>	<u>Description</u>
30	II	Account (#1)	Account ID #1	Assign 4-6 numeric Account ID to be identified with Account #1 monitoring station receiver.
31	II	Account (#1)	Dial-Prefix #1	(OPTIONAL) Set up-to-8-digits to be first dialed by DACT when attempting to call Account #1 monitoring station receiver.
32	II	Account (#1)	Local Number #1	Set up-to-8-digits to be dialed (after Dial-Prefix #1 digits) by DACT when attempting to call Account #1 monitoring station receiver.
33	II	Account (#1)	Report Format #1	Choose report format (Contact ID or SIA) to be generated by DACT when reporting with Account #1 monitoring station receiver.
40	II	Account (#2)	Account ID #2	Assign 4-6 numeric Account ID to be identified with Account #1 monitoring station receiver
41	II	Account (#2)	Dial-Prefix #2	(OPTIONAL) Set up-to-8-digits to be first dialed by DACT when attempting to call Account #2 monitoring station receiver.
42	II	Account (#2)	Local Number #2	Set up-to-8-digits to be dialed (after Dial-Prefix #2 digits) by DACT when attempting to call Account #2 monitoring station receiver.
43	II	Account (#2)	Report Format #2	Choose report format (Contact ID or SIA) to be generated by DACT when reporting with Account #2 monitoring station receiver.
50	II	Report Priority	ALARM Events	Choose which Account # (1 or 2) will be the <i>first</i> to be <i>attempted</i> to be reached by the DACT, when an ALARM event is to be reported. This is designated as the "primary" account and the other will become the "secondary". If the DACT cannot report to the primary, it will then <i>attempt</i> to report to the secondary. This cycle will <i>normally</i> continue until the event is eventually or the <MAXIMUM Attempts> has been achieved.
51	II	Report Priority	TROUBLE Events	Choose which Account # (1 or 2) will be the <i>first</i> to be <i>attempted</i> to be reached by the DACT, when a TROUBLE event is to be reported. (See ITEM 50 for a description of the DACT report-attempt operation).
52	II	Report Priority	SUPERVISORY Events	Choose which Account # (1 or 2) will be the <i>first</i> to be <i>attempted</i> to be reached by the DACT, when a SUPERVISORY event is to be reported. (See ITEM 50 for a description of the DACT report-attempt operation).
53	II	Report Priority	'Must' Report #1	The selection allows the overriding of the "normal" reporting fulfillment strategy. If 'Must' Report #1 is ALWAYS, the DACT will continue to <i>attempt</i> to report each event to Account #1 <i>until successful</i> . This will be the case even if the event has been previously reported to Account #2, and even if the DACT has also exceeded MAX attempts. (see ITEM 55).
54	II	Report Priority	'Must' Report #2	The selection allows the overriding of the "normal" reporting fulfillment strategy. If 'Must' Report #2 is ALWAYS, the DACT will continue to <i>attempt</i> to report each event to Account #2 <i>until successful</i> . This will be the case even if the event has been previously reported to Account #1, and even if the DACT has also exceeded MAX attempts. (see ITEM 55).
55	II	Report Priority	Max. Attempts	Set the "normal" upper limit for DACT attempts (<u>call-attempt pairs</u>) to report to monitoring station receivers. (See ITEM 50 for a description of the DACT report-attempt operation). After this count has been exceeded, the DACT will assert the TROUBLE-SEND signal (and BUZZER) to the connected Fire-Panel.
60	II	Phone Line (1/2)	Dial-type Line 1	Configure Line 1 for DTMF (Tone) or Rotary (Pulse) dialing. The choice of which line to be used when the DACT is reporting normally alternates between Line 1/2 with each call-attempt.
61	II	Phone Line (1/2)	Dial-type Line 2	Configure Line 2 for DTMF (Tone) or Rotary (Pulse) dialing. The choice of which line to be used when the DACT is reporting normally alternates between Line 1/2 with each call-attempt.

NOTE: All items to be configured have default values assigned by the “Restore-to-Default” operation. All items must have a (non-zero) value assigned unless specifically identified as OPTIONAL within the table(s) above.

REPORTING FORMATS

ADEMCO CONTACT-ID

DACT Internal Events (All Models):

Event Description	Event Family	Qualifier	Code	Group #	Contact #
Phone Line #1 trouble detected	Trouble	New event	351	00	000
Phone Line #2 trouble detected	Trouble	New event	352	00	000
Phone Line #1 trouble restored	Trouble	Restore	351	00	000
Phone Line #2 trouble restored	Trouble	Restore	352	00	000
Failure to report to an Account	Trouble	New event	354	Acct #	Acct #
Report to an Account successful	Trouble	Restore	354	Acct #	Acct #
Periodic (24 hr) Test Event (All Normal)	Test	New event	602	00	000
Periodic (24 hr) Test Event (Off Normal)	Test	New event	608	00	000
Manually initiated dialer test	Test	New event	601	00	000

DACT External Events (FW-DACT):

Event Description	Event Family	Qualifier	Code	Group #	Contact #
Fire Alarm	Alarm	New event	110	00	000
Fire Alarm restored	Alarm	Restore	110	00	000
System Trouble detected	Trouble	New event	300	00	000
System Trouble restored	Trouble	Restore	300	00	000
Supervisory condition	Supervisory	New event	200	00	000
Supervisory restored	Supervisory	Restore	200	00	000

SECURITY INDUSTRIES ASSOC. SIA-DCS

DACT Internal Events :

Event Description	Event Family	Qualifier	SIA Event Code	Parameter
Phone Line #1 trouble detected	Trouble	New event	LT	Line #
Phone Line #2 trouble detected	Trouble	New event	LT	Line #
Phone Line #1 trouble restored	Trouble	Restore	LR	Line #
Phone Line #2 trouble restored	Trouble	Restore	LR	Line #
Failure to report to an Account	Trouble	New event	RT	Acct #
Report to an Account successful	Trouble	Restore	YK	Acct #
Periodic (24 hr) Test Event (All Normal)	Test	New event	RP	00

Periodic (24 hr) Test Event (Off Normal)	Test	New event	RP	01
Manually initiated dialer test	Test	New event	RX	00

DACT External Events (FW-DACT):

Event Description	Event Family	Qualifier	SIA Event Code	Parameter
Fire Alarm	Alarm	New event	FA	00
Fire Alarm restored	Alarm	Restore	FH	00
System Trouble detected	Trouble	New event	FT	00
System Trouble restored	Trouble	Restore	FJ	00
Supervisory condition	Supervisory	New event	SS	00
Supervisory restored	Supervisory	Restore	SR	00

COMPATIBLE FIRE ALARM CONTROL PANELS

NAPCO FW-DACT: Compatible with **NAPCO FW-C2Z, FW-C4Z, FW-C4EZ** Fire Alarm Control Panels.

COMPATIBLE RECEIVERS

The **NAPCO FW-DACT** is compatible with the following **Digital Alarm Communicator Receivers (DACR)** ...

DACR Receiver Model

- SurGard MLR2 Multi-Line Receiver (ULC, ULI Approved)**
- Osborne-Hoffman Quickalert! II Receiver (ULI Approved)**
- Osborne-Hoffman OH-2000 Receiver (ULI Approved)**

Protocols

- SIA-DCS and Ademco Contact ID**
- SIA-DCS and Ademco Contact ID**
- SIA-DCS and Ademco Contact ID**

SPECIFICATIONS

All Circuits are Power Limited

FW-DACT Digital Communicator:

- M Connects to two Telephone Lines and performs both DC and Dial Tone Supervision.
- M Connects to a NAPCO FACP via a ribbon cable. This connection provides DC power and all signalling between the Communicator and the FACP.
- M Transmits Common Alarm, Supervisory, and Trouble status to a Central Monitoring Station, using either Ademco Contact ID or SIA DCS Protocols.
- M User configured using the FW-PCTOOL Configuration Tool, with three levels of Password control.
- M Current Consumption: Standby: See compatible Fire Alarm Control Panel - Installation and Operation Manual.

BATTERY CALCULATIONS

FW-DACT:

*The **FW-DACT** Battery Calculations are performed as part of the calculations for the Fire Alarm Control Panel it will be used in. See the appropriate NAPCO Installation and Operation Manual.*

WARRANTY

NAPCO SECURITY SYSTEMS, INC. (NAPCO) warrants its products to be free from manufacturing defects in materials and workmanship for 12 months following the date of manufacture. NAPCO will, within said period, at its option, repair or replace any product failing to operate correctly without charge to the original purchaser or user.

This warranty shall not apply to any equipment, or any part thereof, which has been repaired by others, improperly installed, improperly used, abused, altered, damaged, subjected to acts of God, or on which any serial numbers have been altered, defaced or removed. Seller will not be responsible for any dismantling or reinstallation charges.

THERE ARE NO WARRANTIES, EXPRESS OR IMPLIED, WHICH EXTEND BEYOND THE DESCRIPTION ON THE FACE HEREOF. THERE IS NO EXPRESS OR IMPLIED WARRANTY OF MERCHANTABILITY OR A WARRANTY OF FITNESS FOR A PARTICULAR PURPOSE. ADDITIONALLY, THIS WARRANTY IS IN LIEU OF ALL OTHER OBLIGATIONS OR LIABILITIES ON THE PART OF NAPCO.

Any action for breach of warranty, including but not limited to any implied warranty of merchantability, must be brought within the six months following the end of the warranty period.

IN NO CASE SHALL NAPCO BE LIABLE TO ANYONE FOR ANY CONSEQUENTIAL OR INCIDENTAL DAMAGES FOR BREACH OF THIS OR ANY OTHER WARRANTY, EXPRESS OR IMPLIED, EVEN IF THE LOSS OR DAMAGE IS CAUSED BY THE SELLER'S OWN NEGLIGENCE OR FAULT.

In case of defect, contact the security professional who installed and maintains your security system. In order to exercise the warranty, the product must be returned by the security professional, shipping costs prepaid and insured to NAPCO. After repair or replacement, NAPCO assumes the cost of returning products under warranty. NAPCO shall have no obligation under this warranty, or otherwise, if the product has been repaired

by others, improperly used, abused, altered, damaged, subjected to accident, nuisance, flood, fire or acts of God, or on which any serial numbers have been altered, defaced or removed. NAPCO will not be responsible for any dismantling, reassembly or reinstallation charges.

This warranty contains the entire warranty. It is the sole warranty and any prior agreements or representations, whether oral or written, are either merged herein or are expressly cancelled. NAPCO neither assumes, nor authorizes any other person purporting to act on its behalf to modify, to change, or to assume for it, any other warranty or liability concerning its products.

In no event shall NAPCO be liable for an amount in excess of NAPCO's original selling price of the product, for any loss or damage, whether direct, indirect, incidental, consequential, or otherwise arising out of any failure of the product. Seller's warranty, was herein above set forth, shall not be enlarged, diminished or affected by and no obligation or liability shall arise or grow out of Seller's rendering of technical advice or service in connection with Buyer's order of the goods furnished hereunder.

NAPCO RECOMMENDS THAT THE ENTIRE SYSTEM BE COMPLETELY TESTED WEEKLY.

Warning: Despite frequent testing, and due to, but not limited to, any or all of the following; criminal tampering, electrical or communications disruption, it is possible for the system to fail to perform as expected. NAPCO does not represent that the product/system may not be compromised or circumvented; or that the product or system will prevent any personal injury or property loss by burglary, robbery, fire or otherwise; nor that the product or system will in all cases provide adequate warning or protection. A properly installed and maintained alarm may only reduce risk of burglary, robbery, fire or otherwise but it is not insurance or a guarantee that these events will not occur. CONSEQUENTLY, SELLER SHALL HAVE NO LIABILITY FOR ANY PERSONAL INJURY, PROPERTY DAMAGE, OR OTHER LOSS BASED ON A CLAIM THE PRODUCT FAILED TO GIVE WARNING.

Therefore, the installer should in turn advise the consumer to take any and all precautions for his or her safety including, but not limited to, fleeing the premises and calling police or fire department, in order to mitigate the possibilities of harm and/or damage.

NAPCO is not an insurer of either the property or safety of the user's family of employees, and limits its liability for any loss or damage including incidental or consequential damages to NAPCO's original selling price of the product regardless of the cause of such loss or damage.

Some states do not allow limitations on how long an

implied warranty lasts or do not allow the exclusions or limitation of incidental or consequential damages, or differentiate in their treatment of limitations of liability for ordinary or gross negligence, so the above limitations or exclusions may not apply to you. This warranty gives you specific legal rights and you may also have other rights which vary from state to state.

Head Office:
FIREWOLF Advanced Fire Products
NAPCO Security Systems, Inc.
333 Bayview Avenue
AMITYVILLE, N.Y.
U.S.A. 11701
Phone: (516) 842-9400
IN NORTH AMERICA Phone: 1-800-645-9445
FAX Toll Free: (516) 789-9292
Web Page: <http://www.napcosecurity.com>
e-mail: techinfo@napcosecurity.com