

FREEDOM F-LTRANS WIRELESS LOCK TRANSMITTER INSTALLATION INSTRUCTIONS

GENERAL DESCRIPTION

The Freedom F-LTRANS wireless lock transmitter is designed for use with the F-TP Touchpad's internal wireless receiver, which is wired to the F-8 Control Panel. The F-LTRANS wireless transmitter is used with the F-TAB deadbolt sensor and a N/C magnetic door contact, sending the status of the deadbolt (locked/unlocked) and the associated door (open/closed) to the receiver in the F-TP Touchpad.

The F-LTRANS wireless transmitter is powered by a 3-volt Type DL123A lithium battery, which will power the transmitter for up to 5 years. When battery

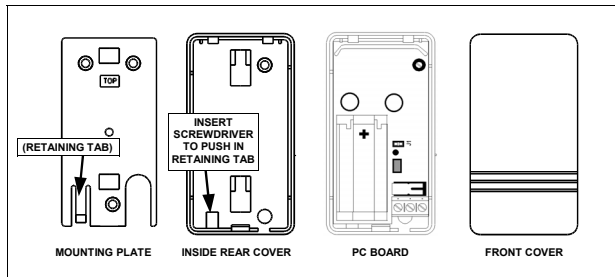

Fig. 1. F-LTRANS Wireless Transmitter Component Parts

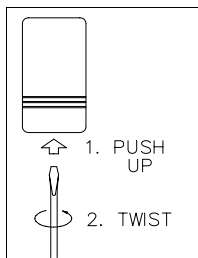

Fig. 2. Opening the case

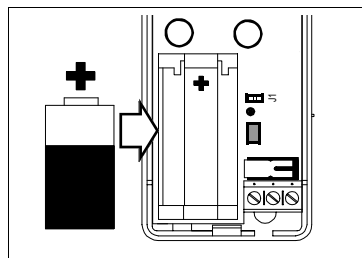

Fig. 3. Installing the battery

voltage drops below normal, a low-battery report will be sent to the receiver. Each F-LTRANS wireless transmitter has a unique factory-programmed code that distinguishes itself to the receiver.

TRANSMITTER AND RECEIVER OPERATION

When learning transmitters into the F-TP Touchpad receiver, it is necessary to keep the Touchpad faceplate open in order to examine the receiver LED and operate the Mode button (with a pen tip). There are three receiver Modes: **Learn Mode**, **Replace Mode**, and **Clear Mode**.

Learn Mode

Learn Mode allows the learning of the first F-LTRANS wireless transmitter detected by the receiver. To make learning transmitters as easy as possible, when power is first applied to the F-TP Touchpad, the receiver LED flashes rapidly, indicating the Touchpad receiver is in Learn Mode. The LED **not** flashing upon power-up indicates the presence of a previously learned transmitter within the Touchpad receiver. *In Learn Mode, you cannot re-learn a transmitter that has previously been learned.* You will either need to clear ALL data from the receiver, or add a second transmitter to the receiver.

- To clear all data, refer to the Clear Mode section below.
- To learn a Secondary transmitter, press the Mode Button to re-start Learn Mode (the LED will begin to flash rapidly) and a Secondary transmitter can be learned. See page 5, step 17 for this procedure.

Learn Mode is used when installing new systems, or adding a new Secondary transmitter to an existing system.

Replace Mode

Replace Mode is used when an *existing* transmitter within an *existing* system must be replaced. Replace Mode allows a new transmitter to replace

(overwrite) existing transmitter data. To enter Replace Mode, start in Learn Mode (rapid flashing), then press the Mode Button again (with a pen tip) and the receiver will slowly flash. This slowly flashing LED indicates the receiver is in Learn Mode. The receiver will overwrite either the Primary or Secondary transmitter data, depending on the state of the transmitter shunt connector (if the shunt connector is removed from the address jumper, the Primary transmitter will be overwritten; if the shunt connector is placed on the address jumper, the Secondary transmitter will be overwritten).

Clear Mode

You can erase ALL pre-existing transmitter data from the receiver Touchpad at any time. Simply press and hold the Mode Button (about 6 seconds—use a pen tip) until the LED turns on steady. (While holding the Mode Button, the LED will flash rapidly—after about 6 seconds the LED will then turn on steady). Release the button and the LED will resume flashing rapidly, indicating the receiver is once again in Learn Mode with all pre-existing data erased.

INSTALLING A SECOND F-LTRANS

The wireless Freedom system can include up to two F-TP Touchpads, and each wireless Touchpad can include up to two F-LTRANS wireless transmitters supervising two doors.

IMPORTANT: With a single F-TP Touchpad installation with two doors protected by two transmitters, one transmitter must be configured as a Primary (NO shunt connector installed into the address jumper) and the other transmitter must be configured as a Secondary (with the shunt connector installed). The Primary transmitter should always be installed to protect the door most often used to ARM the system and EXIT the premises. The Secondary transmitter should be used to protect a second door that will be used only for ENTRY (or to disarm when armed Stay).

Although the Secondary door can, in theory, be used as an exit door, to do so you must always be certain the Primary door deadbolt is locked before arming, thus defeating the foolproof nature of the Freedom system. The Ready light will NOT indicate the status of the Primary door deadbolt (the Ready light will ONLY indicate the status of the Secondary door deadbolt). Therefore, *pressing Away and exiting through the Secondary door (with the Primary door deadbolt remaining unlocked) will result in the system automatically reverting to an unarmed state after the exit delay expires.* As a result, the homeowner should be instructed to use the door protected by the Secondary transmitter FOR ENTRY ONLY (or to disarm when armed Stay).

Similarly, with a single F-TP Touchpad installation with one exit door protected by one transmitter, the Ready light will always be on regardless of the position of the protected deadbolt. This is designed to allow the arming of the system with the exit door open.

Furthermore, because the Touchpad integral PIR may not always be able to supervise the Secondary transmitter, care must be taken to ensure an intruder can not disarm the system by turning the deadbolt latch at the Secondary transmitter. Using an additional PIR to generate an alarm before the intruder can turn the deadbolt latch may not be sufficient (standard PIR's false alarm features may cause it to take too long to detect an intruder). Additional perimeter and/or interior intruder detection devices, such as window foil, glass breaks or additional PIR's, may be required to ensure the intruder will be detected by the system before the deadbolt latch at the Secondary transmitter can be thrown. **Note:** If the Secondary transmitter deadbolt is unlocked, the READY light will be out; if the READY light is out when attempting to arm the system, all monitored deadbolts (except at the primary door) **must** be examined and locked before the system can be armed.

Test the Secondary Transmitter

The Secondary transmitter should always be tested prior to installation, as follows: After installing and learning the Primary transmitter, place the Secondary transmitter in the selected mounting location and remove the cover. Remove the F-TP Touchpad from its backplate and have someone observe the receiver LED as the Secondary transmitter tamper switch is pressed and released. The receiver LED should flicker several times. If it does not, try another mounting location. If a location cannot be found, a second F-TP Touchpad must be used.

MOUNT AND WIRE THE F-TAB SENSOR AND WIRE THE DOOR SENSOR TO THE F-LTRANS

1 These instructions will show you how to mount and wire the **F-TAB Sensor** and the F-LTRANS wireless transmitter.

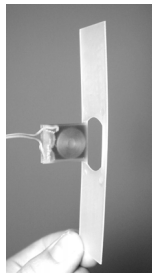

F-TAB Deadbolt Sensor

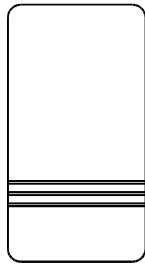

F-LTRANS Wireless Transmitter

2 Remove the strike plate

Remove the two screws securing the deadbolt strike plate to the door frame. If there is a dust cup installed, it must be removed.

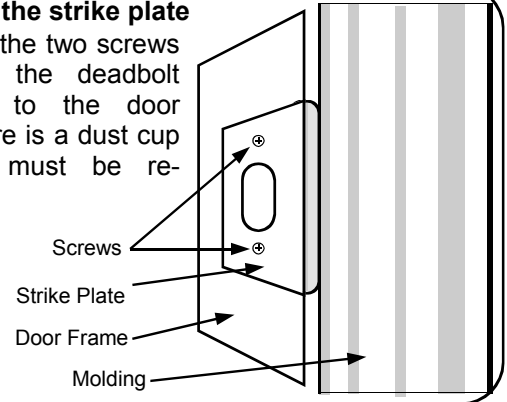

3 Test fit the F-TAB into the deadbolt strike hole. For increased kick-in protection, place the F-TAB sensor "tab" closer to the inside (protected) side of the premises. Determine if the deadbolt hole will need enlarging. The F-TAB requires a depth of approximately 1". In addition, one side of the deadbolt hole must be enlarged to accommodate the F-TAB sensor "tab".

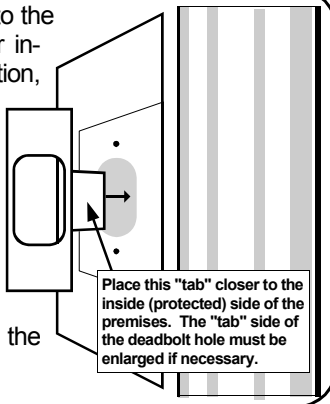

4 Enlarge the deadbolt hole using the supplied drilling guide. Secure the drilling guide to the bolt hole using the strike plate screws. With a 1/4" bit, hold the drill level and drill through the (2) holes of the guide matching the location of the F-TAB sensor "tab" to a depth of approximately 1 1/2".

Remove the drill guide when done.

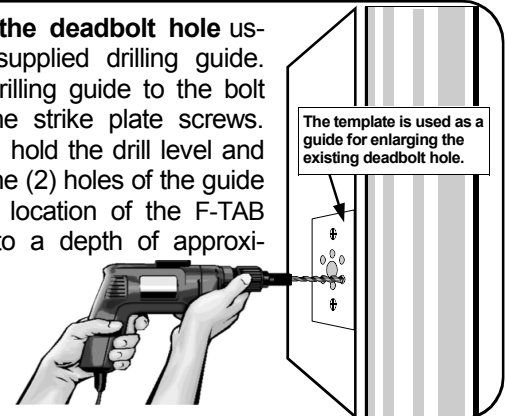

5 To increase the depth of the deadbolt hole, use a 1" spade bit (shown).

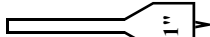

Remove the remaining wood from the deadbolt hole opening using a rotary wood rasp or wood chisel. The opening must not obstruct the installed F-TAB or the closed deadbolt.



6 Locate the F-LTRANS wireless transmitter:

Mount the F-LTRANS wireless transmitter inside a drop ceiling, above the door frame, or in any location suitable for the installation (see illustration). Using its mounting base as a template, mark the mounting holes and wire access hole (leaving at least 3/4" from the edge of the door molding to allow for the greater width of the F-LTRANS case). Drill the wire access hole as necessary.

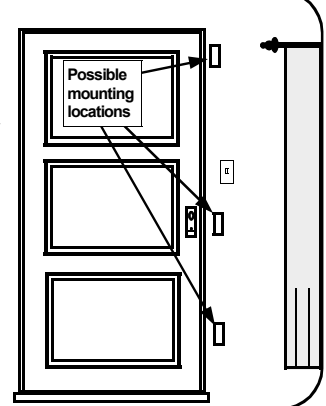

7 Drill access hole for F-TAB

Drill a 3/8" hole in the deadbolt opening (A) for a two conductor wire to be run from the F-TAB to the edge of the door jamb. From this point, the wire can emerge from the wall and be placed next to the door jamb or can continue through the wall to the F-LTRANS wireless transmitter, as necessary.

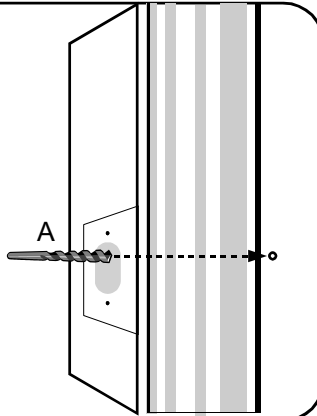

8 Drill Door Contact Hole

Drill a hole (B) for a 3/8" recessed door contact sensor. To maintain Door Kick-in Protection, the contact sensor must be placed on the "latch side" of the inside door frame or the top of the door frame (header). Install the door contact magnet into the door. When the door is closed, the magnet must be adjacent to the contact sensor. **Warning:** When drilling through door frame, always stay clear of high voltage wiring which may be present in the wall cavity.

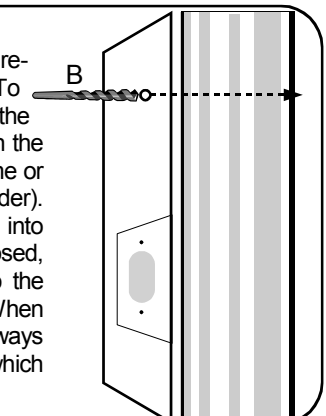

9 Install Recessed Door Contact

The door contact sensor wires must be connected to the F-LTRANS wireless transmitter.

Insert wire snake into the F-LTRANS wire access hole and out through the door contact sensor hole in the door frame. Connect the end of the contact sensor wires to the wire snake and pull wires into door frame and out the F-LTRANS wireless transmitter wire access hole in wall.

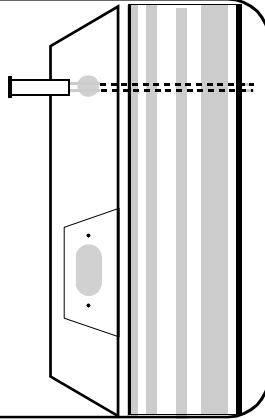

10 Install F-TAB

Using a wire snake, pull wire from the dead-bolt strike hole and into the F-LTRANS wireless transmitter wire access hole in wall. Place the F-TAB into deadbolt hole. If the plastic F-TAB flanges protrude past the area covered by the strike plate, it may be trimmed with a knife (see image).

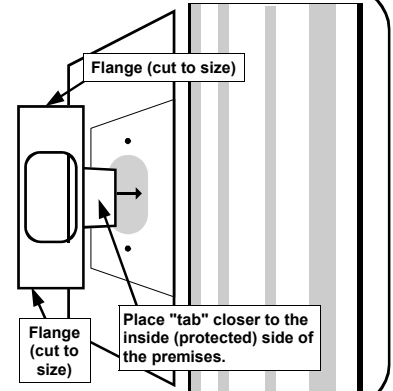

11 Install strike plate

Place strike plate over the F-TAB. Align properly over screw holes and punch through the plastic flange of the F-TAB with an awl or other sharp tool. Replace the 2 screws to secure the strike plate. Ensure that the F-TAB hole is centered in the strike plate opening.

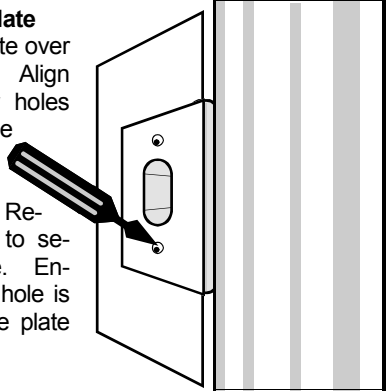

12 Install the F-LTRANS

(Note: Do NOT install battery until wiring is complete). Mount the Transmitter base (screws provided) with all wires from the wall hidden under the Transmitter. Wire the F-LTRANS transmitter:

- Twist together one wire from the F-TAB and one from the door contact and screw into center terminal.
 - Insert the remaining F-TAB wire into the left terminal and secure.
 - Insert the remaining door contact wire into the right terminal and secure.
- Do NOT install the F-LTRANS cover.

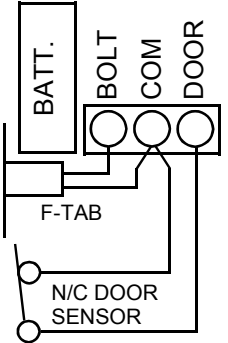

LEARN F-LTRANS WIRELESS TRANSMITTERS AND TEST SYSTEM

13 Multiple Transmitters--Notes

The Primary transmitter that is located in the same room as the Touchpad is designated as "Transmitter #1", and its jumper must **NOT** be installed.

If there is a Secondary transmitter installed ("Transmitter #2"), it MUST have a shunt on the Address jumper. See page 4 for more information. **Remove all transmitter covers before proceeding.**

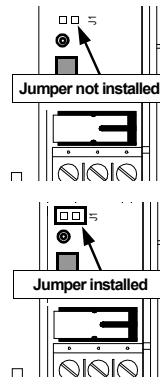

14 Prepare Receiver to Learn Transmitters

With all wiring in place, apply power to the control panel. (the Touchpad receiver will power up) To ensure that the receiver is cleared of all data, use a pen tip to push and hold the button in the center of the Touchpad (see illustration) until the LED is on steady, then release the button. The LED will start flashing, indicating the receiver is in Learn Mode and ready to learn new transmitters.

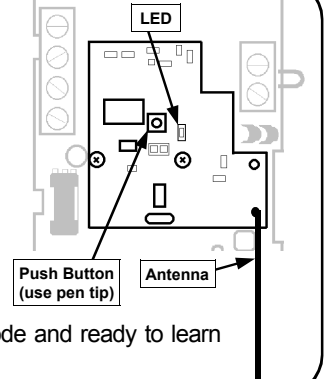

15 Test F-LTRANS wireless transmitter

Note: F-LTRANS wireless transmitters CANNOT be programmed with their covers on. Remove all F-LTRANS transmitter covers.

Unlock and open door. While pressing and holding the tamper switch, insert battery (as shown), then release the tamper switch.

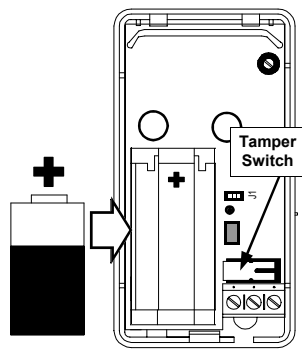

16 (Cont'd)

For a few seconds, the transmitter will begin a self-diagnostic process, then the LED inside the F-LTRANS wireless transmitter will flicker, indicating the F-LTRANS is transmitting a signal to the receiver.

The Touchpad LED will stop flickering and a chime will sound--indicating that the F-LTRANS wireless transmitter is successfully programmed into the Touchpad memory.

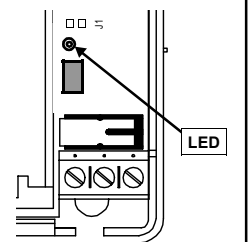

17 Test Transmitters

1. Close the door. The F-TP Touchpad cover should indicate "Ready".
2. Press **STAY** (the STAY light flashes).
3. Engage the deadbolt. Both the ARMED and STAY lights on the Touchpad should turn on (the system armed STAY).
4. Disengage the deadbolt and the system should disarm and turn back off (READY light turns on).
5. Open the door. The Touchpad should sound a chime.

If there is a problem, see Troubleshooting on page 9.

To learn a second transmitter, start again at step 17.

18 Test Transmitter Signal Level

Test the F-LTRANS wireless transmitter to confirm signal strength. Press and release the tamper switch. The receiver LED should flicker in unison with the transmitter LED; if not, there is a problem with the installation (see Troubleshooting on page 9).

Close the Transmitter Case

Snap the front of the F-LTRANS wireless transmitter cover onto the base by inserting the 2 slots in the top onto the corresponding tabs on the base and then snapping the bottom into place.

19 IMPORTANT: Seal access holes

First create a service loop of wires that is long enough to allow the receiver button to be pressed and the LED to be observed. Then seal the access holes with putty (supplied) to ensure F-TP Touchpad is air tight. This important step is necessary to prevent air drafts from entering the F-TP Touchpad from the wall cavity.

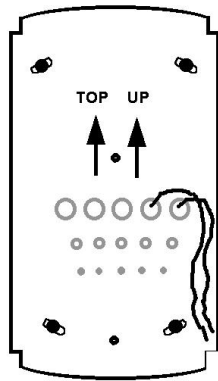

20 Install the F-TP Touchpad Face

Double-check all connections to the F-TP Touchpad using the wiring diagram as a guide. The antenna must be carefully pushed through the hole in the case and dangle down the inside of the wall (see step 3). Snap the front of the F-TP Touchpad onto the base by first inserting the 2 slots in the top onto the corresponding tabs on the base and then snapping the bottom into place.



F-TP Touchpad Wiring Diagram

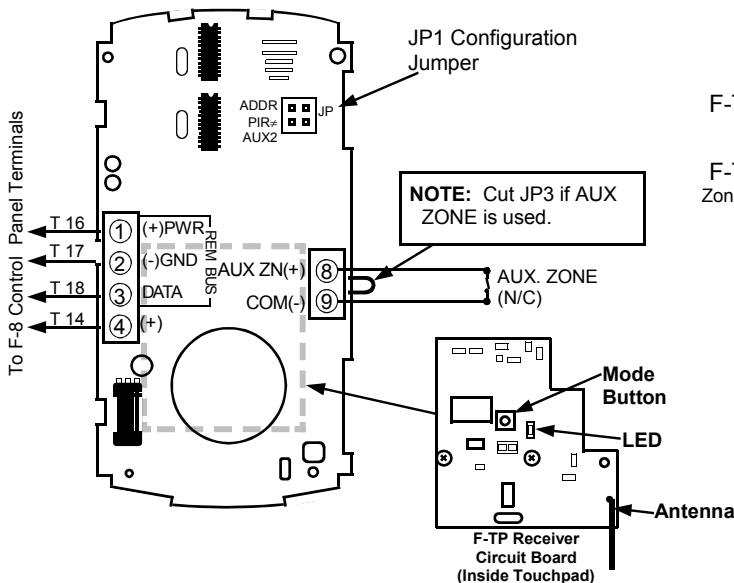

F-TP Touchpad Configuration Jumper JP1

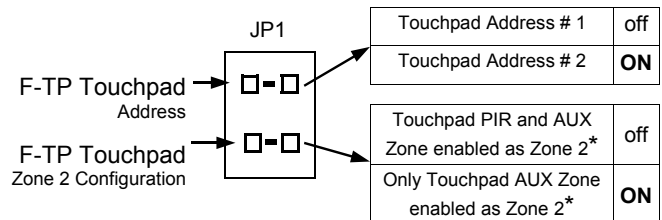

* If AUX ZONE is used, cut Jumper 3 (JP3).

NAPCO Security Group
 333 Bayview Avenue
 Amityville, New York 11701
 For Sales and Repairs, (800) 645-9445
 For Technical Service, (800) 645-9440

Publicly traded on NASDAQ Symbol: NSSC