



OPERATING AND INSTALLATION INSTRUCTIONS

MAGNUM ALERT-825HS ALARM CONTROL CENTER & DIGITAL COMMUNICATOR

Table of Contents

Section	Page
1. INTRODUCTION.....	2
GENERAL DESCRIPTION.....	2
FEATURES.....	3
SPECIFICATIONS.....	5
ORDERING INFORMATION.....	6
2. CONTROLS & INDICATORS.....	7
DIGITAL KEYPAD.....	7
CONTROL CENTER.....	9
3. BASIC OPERATION.....	10
POWER-UP SEQUENCE.....	10
PERSONAL CODES.....	10
AC-FAILURE INDICATION.....	11
ARMING & DISARMING THE SYSTEM.....	11
AMBUSH ZONE.....	11
PANIC ZONE.....	11
4. PROM PROGRAMMING.....	12
PROGRAMMING MATERIALS.....	12
PROGRAMMING STEPS.....	12
PROGRAMMING RECORD SHEETS.....	14
GLOSSARY & PROGRAMMING DATA.....	16
5. INSTALLATION.....	39
CONTROL-CENTER MOUNTING.....	39
GROUNDING.....	39
TAMPER SWITCHES.....	39
KEYPAD MOUNTING.....	40
TESTING THE SYSTEM.....	42
SELECTING FEATURES & WIRING OPTIONS.....	42
WIRING DIAGRAM.....	46

(SEE PAGE 38 FOR A SUMMARY OF CHANGES FROM THE PREVIOUS EDITION)

U.L. LISTED: HOUSEHOLD FIRE AND BURGLARY WARNING SYSTEM CONTROL UNIT

(c) NAPCO 1986

WI373B 11/86

1. INTRODUCTION

GENERAL DESCRIPTION

The MAGNUM ALERT-825HS is a microcomputer-based six-zone commercial and residential control center (for U.L. installations, residential only) with provisions for Ambush/Panic and Auxiliary Zones. The system is contained within a wall-mounted enclosure and includes an integral digital communicator (not evaluated by U.L.), an integrated siren driver, a multifunction digital keypad, a transformer, a battery, and a partially-programmed PROM (programmable read-only memory) integrated circuit.

The digital keypad allows the user to perform the following functions:

- * arm and disarm the system,
- * check the status of each zone,
- * check which zones were violated after an alarm,
- * temporarily shunt one or more zones,
- * send a Panic or Ambush alarm,
- * cancel exit/entry delay,
- * test the alarm output,
- * bypass a Priority-with-Bypass Zone,
- * turn the Door Chime feature on/off, and
- * reset Ac-Failure indication, Day Zone, and Door Chime

Three LEDs and a Mini-Sounder on the keypad provide visual and audible system and individual-zone status information. Digit keys have secondary functions that are accessed by holding down the key until the Mini-Sounder beeps, and are therefore termed "hold-down" functions. The following hold-down functions are provided:

- Key [1] - Alarm/Battery Test
- Key [2] - Alarm History (indicates last alarm condition)
- Key [3] - STATUS LED Flashing off/on
- Key [4] - Instant Alarm (cancels entry delay)
- Key [5] - Door Chime on/off
- Key [9] - Reset Ac-Fail Indication, Day Zone or Door Chime
Bypass Priority-with-Bypass Zone
- Key [S] - Display shunted zones

The PROM is programmed for the particular installation to establish its specific alarm and reporting features.

NOTE: Where permissible by local codes, the MA-825HS may be used with an RP-1003U Fire Supervision and Indicator Station to form a combination fire and burglary control center. Refer to the instruction manual furnished with the RP-1003U (WI279) for details of operation.

FEATURES

Protection Zones

- * Six zones including Ambush/Panic and Auxiliary Zones.
- * Programmable for Exit/Entry Delay and Exit/Entry Follower.
- * Burglary Zone options include:

- Priority or Priority with Bypass
- Manual Selective or Group Shunting
- 24-Hour Protection
- Day Zone Supervision
- Auto Reset
- Preprogrammed Auto Shunt, removable
- 50mS or 7mS Loop Response (normally 750mS)
- Programmable Abort Delay

Alarm Outputs

- * Programmable Sweep Siren
- * Programmable Steady Siren
- * Programmable Pulsing Bell
- * Programmable Output-2 Relay
- * Mini-Sounder on Alarm

Keypad Functions

- * Digit Keypad permits:

- Arm/Disarm Code Selection of up to 4 codes, up to 4 digits each
- Digital Code Entry to arm/disarm system
- Selective and Group Shunt Selection
- Panic Zone Activation
- Hold-Down Function Access

- * LEDs display:

- Alarm State (armed/disarmed) (ARMED/MEMORY)
- Zone Status (STATUS)
- Zones Shunted (SHUNT)
- Alarm History (ARMED/MEMORY)

* Mini-Sounder indicates:

Entry Delay in progress
Entry Door Opened while Disarmed (Door Chime)
System Armed with a Zone in Trouble
Day Zone in Trouble
Arming with a Zone Auto-Shunted
Zone in Alarm (optional)
Low-Battery Alarm (optional)

Communicator Features (Communicator not evaluated by U.L.)

- * Integrated digital communicator with true dial-tone detection, double-pole line seizure and anti-jam.
- * Programmable abort delay before dialing.
- * Rotary or Touch-Tone dialing available. Rotary dialing available as backup to unsuccessful Touch-Tone dialing.
- * Two telephone numbers and receiver/data formats can be accessed. A single master PROM is compatible with all popular receivers.
- * Two-digit event codes and 4-digit subscriber codes programmable for those receivers accepting these formats.

Reporting Features

- * Report on Alarm
- * Opening and/or Closing Reporting by Individual User
- * Opening Report After Alarm
- * Low-Battery Report
- * Conditional Closing Report; Conditional Closing/Status Report
- * Restoral Report
- * Central-Station Ringback
- * Ambush
- * Backup Reporting
- * Double Reporting
- * Split Reporting

SPECIFICATIONS

Operating Temperature: 0-49 degrees C (32-120 degrees F)
Input Power: 16Vac; 14.4VA Class II step-down transformer
Loop Voltage: 10 to 13Vdc
Loop Current: 6mA each (approx.) at zero resistance
Alarm Output 1: Siren (Steady, Sweep, or Pulsing Sweep):
15W, 8 ohms/30W, 4 ohms; or
Bell (jumper selected): 12Vdc, 2A max.
All alarm outputs timed except Pulsing Sweep.
Alarm Output 2: 12Vdc, 2A max., timed
or
Isolated Contacts: Jumper-selected Output 2 (replaces voltage Alarm Output 2): 24Vdc, 2A, resistive
Regulated Aux. Output: 12Vdc, fused (see Combined Standby Current)
Battery: 12Vdc, 4AH Napco RBAT4, sealed lead-acid, rechargeable (supplied); provides at least 4 hours standby under full load
Low-Battery Signal: 11.0V
Control-Center Standby Current: 200mA
Remote Stations: 5 maximum
Current Requirements: 30mA (Remote Power) + Mini-Sounder (9mA)
Additional Mini-Sounder Output: 20mA maximum
Combined Standby Current: 500mA maximum (Remote Power, Auxiliary)
Zone Resistance: 300 ohms max. series resistance per loop; 10k ohms min. between loops.
Fuses:
Speaker/Bell: 3A
Auxiliary Power: 1A
Out. 2/Siren Driver: 4A
Enclosure Dimensions: 12.6x12.6x3.6" (32x32x9.1cm) (HxWxD)
Shipping Weight: Approx. 15 lb. (6.8kg)

ORDERING INFORMATION

Starred items (*) are U.L.-Listed Accessories

MA-825HS	Alarm control center with integral digital communicator and siren driver; DD494HS PROM; RP-1003H Keypad; RBAT4 Battery; and TRF-8 Transformer
DD494HS	Partially-Programmed PROM (different from DD494)
RBAT4	Rechargeable Battery, Sealed Lead-Acid, 12Vdc, 4AH
RBAT-H1*	Dual Battery Harness
RP-1002	Zone Expansion Indicator Station
RP-1003L*	3-Lamp Remote Keypad Station with Zone Shunting Button and Mini-Sounder (less keypad)
RP-1003U*	Fire Supervision and Indicator Station
RP-1003H/HB*	3-Lamp Remote Digital Keypads with Panic Alarm, Zone Shunting Button and Mini-Sounder. The RP-1003H has a hinged front panel; RP-1003HB is brown. The RP-1008I (white) is illuminated.
RP-1008I*	
RPB-1	Surface Mounting Backplate for RP-1003H & RP-1008I
RPB-2	Double Gang Box for RP-1003H/L & RP-1008I
TPS-2	Tamper Switches, set of 2 (U.L. Listed)
TRF-8	Transformer, 16Vac, 14.4VA (U.L. Listed)
EOLR-8*	6-Zone End-of-Line Resistor Supervisory Module
FT-279*	End-of-Line Relay/Resistor Supervisory Module
GSM-400	Ground-Start Module
H-278*	Line-Reversal Module
OI116	User's Operating Manual
PF155	Programming Record Sheets, 100/pad
PRO-410M	PROM Programmer
DD493BNK	Blank PROM
SDC/825	Briefcase Demonstrator
WD/825	Wall/Counter Display

Recommended U.L.-Listed Devices

Bells	Ademco AB8-12, AB10-12 Amseco MBL-8/12V, MBL-10/12V
Speakers	Ademco 713 Atlas Sound VT-158U
Smoke Detectors	BRK 1812, 2812TH (3 maximum) Pyrotector 300942 (15 maximum) 301942 (15 maximum) 305942 (15 maximum)

2. CONTROLS & INDICATORS

DIGITAL KEYPAD

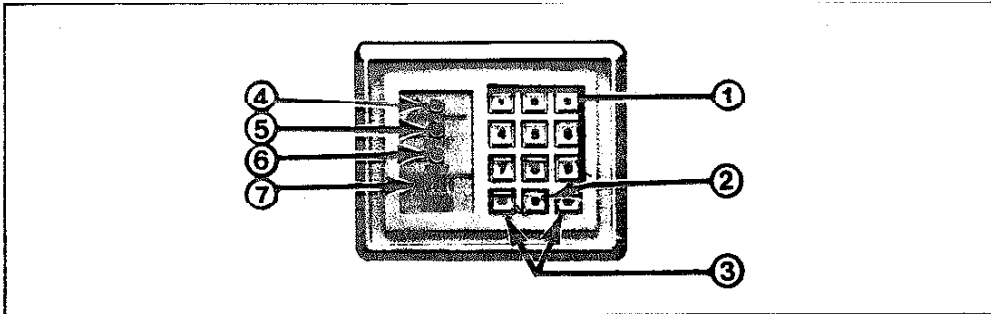

NOTE: Circled numbers below are keyed to those in the illustration above.

Regular Functions

- ① Numerical Keys [1] through [9]. Used for entering arm/disarm code(s) and for selecting zones to be shunted. Also have special Hold-Down Functions as described in **Hold-Down Functions**.
- ② Shunt Key [S]. Used for selecting zones to be shunted. Also has a special Hold-Down Function as described in **Hold-Down Functions**.
- ③ Panic Buttons [*] and [#]. Signal an immediate emergency when *both buttons are pressed at the same time*.
- ④ Red ARMED/MEMORY LED. Glows steadily to indicate that the system is armed. A flashing LED when armed warns that the Control Center was in an alarm condition. It can also indicate which zones were violated (also see **Hold-Down Functions**).
- ⑤ Green STATUS LED. Glows steadily to indicate that all zones are operating properly and the system may be safely armed. A flashing LED warns which non-24-Hour Zone(s) are in trouble (see **Hold-Down Functions**).
- ⑥ Yellow SHUNT LED. Glows steadily to indicate that one or more zones have been shunted and that the system is only partially armed. The LED can flash to indicate which zones have been shunted (see **Hold-Down Functions**).
- ④⑤⑥ All three LEDs flashing together indicates an ac power failure. The control center may be armed while powered by the standby battery as follows: (1) Hold down function Key [1] to test the battery/alarm. After battery operation is confirmed, (2) hold down function Key [9] until it beeps to reset the flashing

LEDs, then enter the arming code.

⑦ Mini-Sounder. Sounds an audible tone whenever

- * an attempt is made to arm the system when a zone is in trouble;
- * entry delay is in progress, to remind the user to disarm the Control Center;
- * a Day Zone is in trouble.

A beep while disarmed indicates that someone has opened the entry door (Door Chime).

A momentary beep when arming indicates that a zone is in trouble and has not been selective or group shunted.

A momentary beep a short time after arming (about 15 seconds to a minute, or so) indicates a central-station ringback if a closing report is programmed.

Hold-Down Functions

In addition to its regular functions, the digital keypad provides a series of dual functions. Note that these functions are accessed by holding down the designated key for about 2 seconds, until a beep sounds from the Mini-Sounder, and are thus known as "Hold-Down" functions.

Key [1] - Test. This will momentarily sound the burglar alarm. A weak alarm may indicate the need for battery replacement. **Instruct the user to make this test weekly.**

Key [2] - Alarm History. This will flash the red ARMED/MEMORY LED to indicate all alarm conditions that have occurred. While holding down Key [2], count the number of flashes to determine the zone(s) violated. After the system is rearmed, the previous alarm will remain in alarm history until automatically reset by a new alarm condition.

Key [3] - STATUS Flashing Off/On. This will stop the STATUS LED flashing. To turn back on, hold down Key [3] again.

Key [4] - Instant Protection. Key [4] will cancel both exit and entry delay periods if pressed before or after arming. This feature may be utilized to sound an instant alarm on intrusion through the Exit/Entry Zone(s). When selected, the red ARMED/MEMORY LED will flash rapidly. Exit/entry delay is automatically reinstated on disarming.

Key [5] - Door Chime Off/On. If Zone 1 is selected as the regular entry door, the Mini-Sounder will "chime" upon entry while disarmed. To enable the Door-Chime feature, hold down Key [5] until it beeps. The duration of the tone is programmable. A lengthy

door "chime" may be silenced by holding down Key [9] until the tone stops.

Key [9] - Reset. This key functions as a general-purpose reset to

- * reset the Ac-Failure indication (all three LEDs blinking);
- * reset a Day-Zone Mini-Sounder indication;
- * reset a lengthy Door Chime; and
- * bypass a troubled zone designated as a Priority-with-Bypass Zone. See Priority Zone With Bypass in the glossary.

Key [S] - Display SHUNT. This will flash the yellow SHUNT LED to indicate the zone(s) shunted. Holding down Key [S], count the number of flashes to determine the zone(s) shunted.

CONTROL CENTER

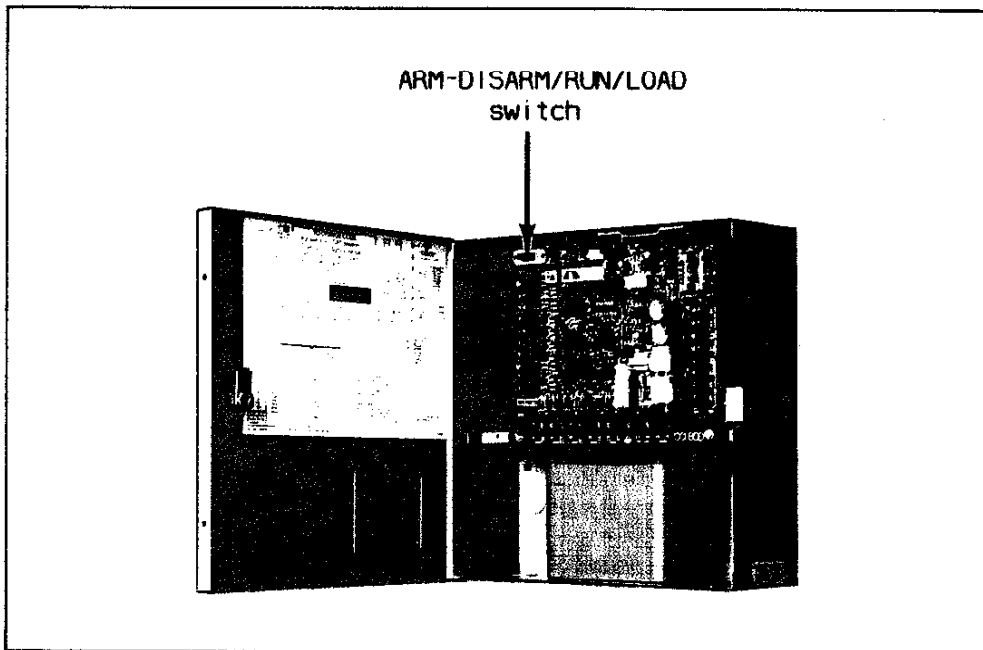

ARM-DISARM/RUN/LOAD Switch. Used to load user arm/disarm codes. This switch is set to the LOAD position when entering personal codes (refer to **Loading Personal Codes**). The switch must be returned to the center (RUN) position after all codes have been entered to resume alarm operation. The system will not operate with the switch in the LOAD position.

Setting this spring-return switch to the left will arm or disarm the system. To defeat this feature, cut Jumper A.

3. BASIC OPERATION

POWER-UP SEQUENCE

1. Before applying power, plug the PROM into the socket on the circuit board.
2. Connect ac power.
3. Install the RBAT4 battery (supplied).
4. Connect the telephone cord to the RJ31X jack.

PERSONAL CODES

Loading Personal Codes

Up to four different personal arm/disarm codes may be loaded into the Control Center using the digital keypad. To program these codes, slide the ARM-DISARM/RUN/LOAD switch (upper left corner of the Control Center) to the right (LOAD) position. The three LEDs on the keypad will flash rapidly, and the Mini-Sounder will beep. At the keypad, enter any combination of up to four digits (there is no zero) as follows:

Press [S] then [1] then [any 4 digits] = first user's code
[S] then [2] then [any 4 digits] = second user's code
[S] then [3] then [any 4 digits] = third user's code
[S] then [4] then [any 4 digits] = fourth user's code

After all user codes have been entered, return the ARM-DISARM/RUN/LOAD switch at the Control Center to the center (RUN) position. *Remember:* the system will not operate with the switch in the LOAD position.

NOTE: It is not necessary to assign all four codes.

The numbers selected become the only codes recognized by the system. Each user should be assigned his own dissimilar code and should be cautioned against divulging that code to anyone else. Thus, should it become necessary to remove a user from the system, that one code may be voided without affecting other codes, and that user would then be prevented from entry.

Changing or Voiding a Code

Changing any user's code is accomplished using the foregoing procedure and simply changing the 4-digit combination. Thus, to change User 3's code:

1. Set the ARM-DISARM/RUN/LOAD switch to LOAD.
2. Press [S] then [3] then [4 new digits] = User 3's new code.
3. Return the ARM-DISARM/RUN/LOAD switch to RUN.

Similarly, User 3's code may be voided by merely eliminating the 4-digit combination. Thus, to void User 3's code:

1. Set the ARM-DISARM/RUN/LOAD switch to LOAD.
2. Press [S] then [3] = User 3's code erased.
3. Return the ARM-DISARM/RUN/LOAD switch to RUN.

AC-FAILURE INDICATION

Loss of ac power will be indicated by all three LEDs flashing simultaneously. Check battery/bell condition with hold-down function Key [1]. Hold down Key [9] to reset the LEDs.

NOTE: If an Instant/Delay (or Home/Away) switch is installed, the Ac-Failure Indication feature is sacrificed.

ARMING & DISARMING THE SYSTEM

When a personal code is entered into the keypad, the red ARMED/MEMORY LED will either come on, indicating that the Control Center is armed; or go off, indicating that the Control Center is disarmed. If a wrong code is entered, the system will fail to respond. *Wait at least 2 seconds* before attempting to re-enter a code.

If the system fails to respond to a correct code, as may occur after an extended power failure, all personal codes have been erased and the Fallback Code must be utilized to arm and disarm.

AMBUSH ZONE

The Ambush Zone may be accessed by the user by entering his Ambush Code just prior to disarming. Thus, should he be forced to disarm by an assailant, the user can silently signal an emergency while appearing to be merely disarming the system. The Arm/Disarm Code must be entered within 8 seconds after the Ambush Code for an ambush report to be transmitted.

PANIC ZONE

The Panic Zone is accessed by simultaneously pressing the two Panic Buttons (Keys [*] and [#] on the keypad) and may be programmed to send a silent alarm to a central station (optional), activate an audible alarm, or both.

NOTE: The [*] and [#] keys must be pressed *at the same time* to activate the Panic Zone.

4. PROM PROGRAMMING

PROGRAMMING MATERIALS

Subscriber PROM. The partially-programmed DD494HS PROM (integrated-circuit) supplied with the control center becomes a subscriber PROM when programmed with the selected features and communicator information required for the installation. The PROM is programmed on a NAPCO PRO-410/410M Programmer. After programming, the subscriber PROM is plugged into the PROM socket on the control-center circuit board.

Glossary. Detailed programming instructions are contained in the **Glossary & Programming Data** section of this manual. Glossary entries are listed in alphanumeric order, not in order of PROM location; PROM locations follow entry where applicable.

Programming Record Sheets. Programming Record Sheets similar to those that follow are completed when planning system features and communicator information for the particular installation. These sheets are used when programming the subscriber PROM, and should be retained for future reference.

PROGRAMMING STEPS

1. Contact the central station to confirm receiver format, data format, event codes, subscriber numbers and telephone number(s). Two receiver descriptions and telephone numbers, and up to 4 Subscriber Identification Numbers may be required.

2. Complete the Programming Record Sheet. Reference record sheets for the MA-825HS are furnished in the following pages. Select the desired features by circling the respective "location" boxes. Refer to the GLOSSARY for guidance in selecting "data" entries.

3. To program the subscriber PROM, follow the instructions furnished with the PRO-410/410M Programmer. Note, however, the PAGE switch on the PRO-410/410M. Factory-programmed data are contained on PROM Page 1, programmable data on Page 0; thus the PAGE switch is normally set to [0]. The PAGE 1 position is used only to alter factory-programmed data in order to accommodate special applications. It is not necessary to copy a NAPCO Master PROM onto the DD494HS PROM supplied with the system. The DD494HS PROM already contains the master information preprogrammed on it. Plug the partially-programmed DD494HS PROM into the PRO-410/410M [SUBSCRIBER] PROM socket.

CAUTION: Before attempting to alter preprogrammed data on Page 1, be sure that all Page 0 data in memory are erased (press [ERASE], then [EXECUTE]). Except for the Page-1 location being programmed,

PROGRAMMING RECORD SHEET FOR THE MAGNUM ALERT-825HS

CUSTOMER:
ADDRESS:
DATE:



FEATURE	1	2	3	4	5	6	LOW BAT
REPORT ON ALARM	120	120	120	120	121	121	121
CONTROL-CENTER RESTORAL ⁽¹⁾	122	122	122	122	123	123	123
ZONE RESTORAL ⁽¹⁾	140	140	140	140	141	141	141
DAY ZONE	142	142	142	142	143	143	143
PRIORITY WITH BYPASS ⁽²⁾	144	144	144	144	145	145	145
PRIORITY	146	146	146	146	147	147	147
REMOVE AUTO-SHUNT ⁽²⁾	148	148	148	148	149	149	149
SELECTIVE SHUNT	150	150	150	150	151	151	
GROUP SHUNT	152	152	152	152	153	153	153
24-HOUR PROTECTION	154	154	154	154	155	155	155
AUTO-RESET	156	156	156	156	157	157	
SWINGER SHUTDOWN	158	158	158	158	159	159	159
EXIT/ENTRY ZONE	160	160	160	160	161	161	
EXIT/ENTRY FOLLOWER	162	162	162	162	163	163	
ABORT DELAY	164	164	164	164	165	165	
ALARM OUTPUT 1 SWEEP SIREN	166	166	166	166	167	167	167
ALARM OUTPUT 1 PULSING BELL	168	168	168	168	169	169	169
ALARM OUTPUT 1 STEADY SIREN	170	170	170	170	171	171	171
ALARM OUTPUT 2 RELAY	172	172	172	172	173	173	173
MINI-SOUNDER ON ALARM	174	174	174	174	175	175	175
7ms LOOP RESPONSE	176	176	176	176	177	177	
50ms LOOP RESPONSE	178	178	178	178	179	179	
INPUT POLARITY	180	180	180	180	181	181	
TOUCH-TONE ^(*) DIALING	130						131
TOUCH-TONE ^(*) ROTARY BACKUP	130	2					132
BACKUP REPORTING	130	4					132
DOUBLE REPORTING	130	8					132
SPLIT REPORTING	131	1					132
OPENING REPORT AFTER ALARM	131	2					133
CONDITIONAL CLOSING REPORT	131	4					133

ZONE							LOW BAT
1	2	3	4	5	6		
120	120	120	120	121	121	121	
122	122	122	122	123	123	123	
140	140	140	140	141	141	141	
142	142	142	142	143	143	143	
144	144	144	144	145	145	145	
146	146	146	146	147	147	147	
148	148	148	148	149	149	149	
150	150	150	150	151	151		
152	152	152	152	153	153	153	
154	154	154	154	155	155	155	
156	156	156	156	157	157		
158	158	158	158	159	159	159	
160	160	160	160	161	161		
162	162	162	162	163	163		
164	164	164	164	165	165		
166	166	166	166	167	167	167	
168	168	168	168	169	169	169	
170	170	170	170	171	171	171	
172	172	172	172	173	173	173	
174	174	174	174	175	175	175	
176	176	176	176	177	177		
178	178	178	178	179	179		
180	180	180	180	181	181		

TIME EXAMPLE CHART		
(seconds or minutes)		
TIME	1st BOX	2nd BOX
5	5	NONE
15	F	NONE
30	E	1
45	d	2
60	C	3

EXIT	ENTRY				
184	185	186	187		

DELAY TIME (seconds)

182	183		
188	189		

ABORT DELAY (seconds)
TIME-OUT (minutes)

190	191		
192	193		

TIME-OUT (minutes)
TIME-OUT (minutes)

RELAY CLOSURE ON ARMING

200	201		
-----	-----	--	--

DOOR-CHIME TIME^(*) (1/4 seconds)

181 COME UP ARMED AFTER POWER FAILURE

PROGRAMMING NOTES	
1.	When programming ZONE RESTORAL, CONTROL-CENTER RESTORAL must also be programmed.
2.	When programming PRIORITY WITH BYPASS, do not program REMOVE AUTO SHUNT.
3.	Example. For 2 seconds, enter "8" in location 200. (See TIME SELECTION)

PROGRAMMING RECORD SHEET FOR THE MAGNUM ALERT-825HS
Communicator Transmission Information

		ZONE						LOW
		1	2	3	4	5	6	BAT
ALARM CODES	Single Digit	000	002	004	006	008	010	012
	Extended or Two Digit	001	003	005	007	009	011	013
RESTORE CODES	Single Digit	024	026	028	030	032	034	036
	Extended or Two Digit	025	027	029	031	033	035	037

OPENING/CLOSING CODES		Closing	Conditional Closing	Opening
Single Digit		User	022	User
		1 2 3 4		1 2 3 4
Extended or Two Digit		014 016 018 020	023 ⁽¹⁾	038 040 042 044
		015 017 019 021		039 041 043 045
	Select User(s) Closing	124 124 124 124 1 2 4 8	Select User(s) Opening	126 126 126 126 1 2 4 8

KEYPAD CODES (Do not enter zeros)

Ambush	194 195	Fallback	196 197 198 199
--------	---------	----------	-----------------

SUBSCRIBER I.D. NUMBERS

	Alarm/Restoral ID	Opening/Closing ID
Telephone 1	060 061 062 063	064 065 066 067
Telephone 2	088 089 090 091	092 093 094 095

	Format Rcvr Data	Pre-Dial Delay	Access Number	Dial-Tone Detection	Telephone Number
Telephone 1	068 069	070	071	072	073 074 075 076 077 078 079 080
Telephone 2	096 097	098	099	100	081 082 083 084 085 086 087
					101 102 103 104 105 106 107 108
					109 110 111 112 113 114 115

ENTRY	RECEIVER FORMAT
Blank	ADEMCO, SILENT KNIGHT "SLOW"
1	SESCOA, VERTEX, DCI, FRANKLIN ⁽²⁾
2	RADIONICS "FAST" ⁽²⁾
3	SILENT KNIGHT "FAST"
4	RADIONICS, DCI, FRANKLIN "SLOW" ⁽²⁾
5	(Reserved)
6	ADEMCO "HI-SPEED" (DTMF)
7	RADIONICS BFSK ⁽²⁾
8	Add for 2300Hz handshake

ENTRY	DATA FORMAT
Blank	Extended or Single Digit
1	Single Digit
2	Two Digit (or 4/2)
4	Sum Check
8	Ademco "HI-SPEED" Sum Check

PROGRAMMING NOTES

- Two-Digit Format only.
- These formats typically use a 2300Hz handshake; add an "8".

GLOSSARY & PROGRAMMING DATA

Abort Delay Before Dialing (Locations 164, 165; 182, 183)

A delay that allows time for the panel to be reset before it reports. Program PROM locations 164, 165 for zone selection; locations 182, 183 for delay time (see Time Selection)

NOTE: If this feature is selected for a 24-Hour Zone, the device and zone must be reset before the transmission is aborted. If the alarm condition is not corrected on a 24-Hour Zone before abort-delay time ends, the communicator will report. If Auto-Reset has also been selected, there will be no report if the zone self-resets before the abort delay time has elapsed.

Access Number for Outside Line (Locations 071, 099)

Some subscribers will have a telephone system that requires one digit to access an outside line before the telephone number can be dialed. Also, the first dial tone encountered (prior to the access number) may have a frequency that is different from that of the accessed dial tone (440Hz). One or more 4-second Pre-Dial Delay "d"s may be entered before the access number instead of a dial tone with frequency "E". See Pre-Dial Delay.

If your subscriber's system uses an access number:

1. Contact the telephone-equipment supplier to find out if a dial tone other than 440Hz is received prior to dialing the access number. If the communicator must delay before dialing the access number instead of attempting to recognize the dial tone, find out how many 4-second delays must be programmed.
2. For Telephone 1,
 - a. Enter the Dial-Tone Detection "E" ([8] [PLUS] [6]) or Pre-Dial Delay "d" ([8] [PLUS] [5]) in location 070. Enter any extra "d"s that may be required starting in location 071.
 - b. Enter the access number digit in location 071, or the first available location thereafter.
 - c. Starting in the first available location after the access number, enter any Pre-Dial Delay "d"s needed before the second dial tone; the detection "E" for the second dial-tone frequency; then the telephone number.
3. If Telephone 2 is used, repeat Step 2 starting in location 098. (See Backup Reporting; Double Reporting; and Split Reporting.) Also see Dial Tone Detection; Pre-Dial Delay.

Alarm Codes See Report on Alarm

Alarm History

Hold-Down Key [2]. This will flash the red ARMED/MEMORY LED to indicate all alarm conditions that have occurred. Count the number of flashes to determine the zone(s) violated. After the system is rearmed, the previous alarm will remain in alarm history until automatically reset by a new alarm condition.

Alarm Outputs (Locations 166-173; 188-193; Terminals 28-32; Jumpers C-E)

The MA-825HS has an integrated siren driver for both burglary and auxiliary alarms, one relay contact output for additional devices, and a communicator that can report alarms to a central station. A bell may be used on the siren output terminals.

The following table summarizes wiring and programming for signaling an alarm in typical installations. See **Time Selection** for time-out durations.

	Output	Wiring	Output Locations	Time-Out Locations	Remarks
OUTPUT 1	Sweep Siren	Speaker on 31/32	166, 167	188, 189	See Note
	Pulsing Bell	Bell on 31/32	168, 169	188, 189	Cut Jumper E
	Steady Siren	Speaker on 31/32	170, 171	190, 191	
	Steady Bell	Bell on 31/32	166, 167	188, 189	Cut Jumper E
	Timed 12V Output 2 Relay	28(-)/29(+)	172, 173	192, 193	
	Timed Isolated Contacts	29/30	172, 173	192, 193	Cut Jumper C
NOTE: Jumper D may be cut to produce a two-tone alternating siren sound.					

Alarm Time-Out (Locations 188, 189; 190, 191; 192,193)

Alarm Time-Out specifies the number of minutes that the alarm will signal before shutting down. If any timed output is selected, the respective Alarm Time-Out must also be programmed. See **Time Selection**.

NOTE: In the State of California, do not program a time out for fire alarms

Ambush Code (Locations 194, 195)

A 1- or 2-digit code that is entered by the user prior to disarming to access the Ambush Zone, causing a silent report to

be sent to a central station. Thus, should a user be forced to disarm by an assailant, he can silently signal an emergency while appearing to be merely disarming the system. Zone 5 is prewired to report an ambush signal. Although the Alarm Code for Zone 5 is used, all features selected for Zone 5 will be independent from Ambush. It is not necessary to program Zone 5 to report on alarm. Also see **Panic Zone**.

To program the ambush feature,

1. Enter 1 or 2 digits as the Ambush Code in locations 194 and 195.
2. Enter an Alarm-Report Code for Ambush on Zone 5 (locations 008 and 009).
3. Inform the user (a) what the Ambush Code is and (b) that the keypad Arm/Disarm Code must be entered within 8 seconds after the Ambush Code for an ambush report to be transmitted.

Anti-Jam Time (Locations 006, 007)

NOTE: The Anti-Jam Time locations are contained on PROM Page 1 (see **PROGRAMMING STEP 3** at the beginning of this section).

If the communicator does not detect a dial tone within 12 seconds, the Anti-Jam feature will be activated. That is, the communicator will go off line for a 16-second anti-jam interval in order to free the telephone circuit from incoming calls, then make another 12-second attempt at dial-tone detection. If still unsuccessful, the communicator will again go off line for 16 seconds, then proceed to dial anyway.

Consult the central station to determine if a longer time is required for the Anti-Jam feature to function. To increase the anti-jam interval from the factory-set 16 seconds to 31 seconds, set the PAGE switch on the PRO-410/410M Programmer to [1], erase memory, and enter an "F" in location 006. (See **CAUTION** after **PROGRAMMING STEP 3** at the beginning of this section.)

To test the Anti-Jam feature, call the alarm phone line from a different phone line, then activate an alarm. The incoming call should be disconnected by the control center.

Auto-Reset (Locations 156, 157)

If a zone signals an alarm and is selected for Auto-Reset, it will automatically rearm itself as soon as the alarm condition is cleared. Zones that are not programmed for Auto-Reset will not be capable of signalling another alarm until (a) the cause of the alarm has been removed from the zone and (b) the zone is manually reset by disarming the control center. See **Swinger Shutdown**. Also see **Abort Delay Before Dialing**.

Auto-Reset After Alarm Time-Out (Location 132)

If the zone activates an alarm output with a programmed time-out period, auto-reset may be set to occur after the time out period. To delay auto-reset until after the alarm times out, program a "2" in location 132.

Auto-Shunt Zone See Remove Auto-Shunt

Backup Reporting (Location 130)

When Backup Reporting is selected and the communicator is unsuccessful in reaching the first telephone number after two attempts, seven attempts will be made to reach the second telephone number.

If Backup Reporting is programmed, enter Subscriber Identification Numbers for Telephone 2 (locations 088-095) and other information required for Telephone 2 (locations 096-115).

NOTE: Subscriber Identification Numbers for both Telephones 1 and 2 must be entered, even if they are the same.

Battery. RBAT4

12Vdc, 4AH standby power source in the control center to provide backup protection in the event of a power loss. One is supplied. A 6AH battery (RBAT6) is available as an option. The battery is an integral part of the system; it *must* be installed, even if ac power is present. Replace the battery every five years.

Closing Report (Location 124)

Conditional Closing Report (Locations 131; 022, 023)

Conditional Closing/Status Report (Locations 131; 000-013; 022, 023)

On arming, the communicator can transmit a closing code for each user, a conditional-closing code, and a status report that identifies the problem zone to the central station. Note that Subscriber Identification Numbers (locations 064-067, 092-095) and Closing Codes (locations 014-021) *must* be entered for any closing report.

Select (Unconditional) Closing Report (location 124) to report each time the control center is armed. Each of up to four users may have his own Closing Code (locations 014-021). Select Conditional Closing ("4" in Location 131) to report only when arming with an auto-shunted zone. This transmission will consist of a Closing Code followed by a the Conditional-Closing Code. Select both to always report on arming, followed by a Conditional-Closing Report if there is a problem.

Select Conditional Closing/Status Report ("8" in location 131) to send a Conditional-Closing followed by a status report that identifies the problem zone(s). The second Alarm-Code location is generally used for this purpose. If this location is vacant, the first location will be used.

A typical Conditional Closing/Status Report is illustrated in the following example.

Example. A burglar breaks into a commercial establishment during the night, breaking the window foil. The Alarm Subscriber Identification Number is "123"; the Alarm Code is "1" (Burglary Zone 1); the Opening/Closing Subscriber Identification Number is "456"; the Conditional-Closing Code is "F"; the Closing Code for User 1 is "C".

The communicator sends the following report to the central station (single-digit data format):

1231 - Sent at the time the alarm occurs.
456C - Closing: The user has returned, inspected the damage and rearmed.
456F - Conditional Closing.
FFF1 - Zone status at time of closing: Window foil still broken. Zone 1 auto-shunts; repair is required.

Come Up Armed After Power Failure (Location 181)

When an "8" is programmed into location 181, the control center will return in an armed state when ac power is restored after an extended power failure (and the backup battery is dead). (The Fallback Code will be required to disarm.)

Conditional Report on Manual Shunt (Location 133)

Normally, when Conditional Closing/Status Report is programmed, only auto-shunted zones are reported. However, when Conditional Report on Manual Shunt is programmed, selective- or group-shunted zones will also cause a trouble status report to be sent. When programming Conditional Report on Manual Shunt, either Conditional Closing Report or Conditional Closing/Status Report must also be programmed.

Control-Center Restoral See Restoral Report

Data Format (Locations 069, 097)

Consult the central station to find out which of the following formats to use.

Extended Format. Extended-format reporting allows the communicator to transmit an extra digit to the central station. This

extra digit is generally used to report the zone on which the alarm occurred; the Alarm Code identifies the type of alarm.

Example. An installation uses the following programmed transmission information: Subscriber Identification Number is "678"; Report on Alarm is selected for Zone 3; Extended Format Alarm Code is "13" (burglary alarm type 1, Zone 3).

If an alarm occurs on Zone 3, the communicator will transmit:

- 6781 - Subscriber "678" reported a burglary alarm.
- 6781 - Repeat of above.
- 1113 - Burglar alarm reported on Zone 3.
- 1113 - Repeat of above.

Extended Format may be used with most central-station receivers. Any receiver capable of recognizing multiple reporting will also recognize Extended Format. The central station will inform you of the event codes to be programmed.

Extended Format does *not* require any programming in locations 069 and 097. To use Extended Format, follow Steps 2 through 5 of **Two-Digit Event-Code Format** later in this section.

Single-Digit Event Code Format. If the receiver cannot accept multiple reporting,

1. Program a "1" in location 069 (and 097 for a second telephone number, if used). See **Double Reporting and Backup Reporting**.
2. Enter the first digit for any Alarm Code, Restore Code, and Opening/Closing Codes.

NOTE: If it is desired to have a Single-Digit Event Code for one telephone number and Extended Format for the other, program both digits for all event codes. Follow Steps 2 through 5 of **Two-Digit Event Code Format**, which follows. The telephone number with a "1" in location 069 (or 097) will transmit only the first digit. The other telephone number will use both digits. (Single-Digit Format will override Two-Digit Format Location 069 or 097.)

Two-Digit Event Code Format. Some central-station receivers require that a two-digit code be sent in each report.

Example. In a certain installation, the Alarm Subscriber Number is "123"; a burglary alarm occurs on Zone 1 (Alarm Code "31"). The communicator will send "12331".

To use Two-Digit Event Code Format,

1. Program a "2" in location 069 (and 097 for a second tele-

phone number, if used). See **Double Reporting; Backup Reporting.**

2. Enter an Alarm Code (locations 000-013) for each zone or condition to report on alarm (see Report on Alarm) or for a Conditional Closing/Status Report as follows:

- a. Enter the first digit of the Alarm Code. (This digit may be used to indicate alarm type.)
- b. Enter the second digit of the Alarm Code. (This digit may be used to indicate the zone.)

3. Repeat Step 2 to enter Restore Codes (locations 024-037) for each zone selected for Control-Center Restoral or Zone Restoral (see Restoral Report).

4. If Opening Report or Opening Report after Alarm is selected, enter a two-digit Opening Code for each user (locations 038-045). See **Opening Report; Opening Report After Alarm.**

5. If a Closing Report is selected, enter a two-digit Closing Code (locations 014-021) for each user. If a Conditional Closing or Conditional Closing/Status Report is selected, also enter a two-digit Conditional-Closing Code (locations 022, 023).

NOTE: Single-Digit Format will override Two-Digit Format in location 069 or 097.

Sum-Check Format. Sum Check is a sophisticated data format used to enhance the speed and check the accuracy of the received transmission. This format should be preferred whenever the central station is capable of receiving it.

After transmitting the Subscriber Identification Number and the event code, the communicator sends a verifying digit that is the sum of both. The receiver compares the verifying digit with the sum of the other two numbers to check transmission accuracy. To select Sum Check, program a "4" (see note below) in location 069 (and 097 for a second telephone number, if used).

NOTE: When using Ademco *Hi-Speed* format, program an "8" (instead of a "4") in location 069 (and 097, if a second telephone number is used).

Day Zone (Locations 142, 143)

A zone programmed to cause visual and audible indication at the keypad if the zone's loop has an abnormal open condition. This feature may be used to warn of trouble during the day, when the control center is not armed. If the Day Zone experiences a problem (a break in a window foil, for example), the green STATUS LED on the keypad will flash the number of the zone in trouble.

and the Mini-Sounder will sound steadily. Hold down Reset Key [9] to reset the Mini-Sounder.

Dial-Tone Detection (Locations 072, 100)

At least one Dial-Tone Detection entry is usually required for each telephone number used to ensure that a dial tone is present before the communicator dials.

When an "E" ([8] [PLUS] [6]) is programmed before the first digit of an outside telephone number, the communicator dial-tone detection circuit is set to detect the standard 440Hz dial tone. The "E" is generally entered in location 072 for Telephone 1 and location 100 for Telephone 2, if used.

It may be necessary to program at least one 4-second Pre-Dial Delay before a Dial-Tone Detection "E". With certain non-standard exchanges, Pre-Dial-Delay "d"s may be used without a Dial-Detection "E". (See Access Number for Outside Line; Pre-Dial Delay.)

Disable Bell Test (Location 132)

Programming an "8" in location 132 will disable Hold-Down Function 1. Do not disable the bell test in U.L. installations.

Door Chime (Zone 1)

This annunciator feature may be used on the regular entry door while disarmed to sound a beep at the keypad upon entry. Hold down Key [5] until the sounder beeps to enable or disable the Door Chime. Chime duration is programmable (locations 200, 201) in units of 1/4 seconds (see Time Selection). To reset a lengthy door "chime", hold down Key [9] until the sounder stops.

Double Reporting (Location 130)

When Double Reporting is selected, information that is successfully sent to Telephone 1 will be sent to Telephone 2 as well.

To program Double Reporting, enter an "8" in location 130. Enter Subscriber Identification Numbers for Telephone 2 (locations 088-095) and related data for Telephone 2 (locations 096-115).

NOTE: Subscriber Identification Numbers for both Telephones 1 and 2 *must* be entered, even if they are the same. Also, if Double Reporting is selected, do not select Split Reporting or Backup Reporting.

"E" Lugs (E3, E4, E9, E10, E13)

- E3 - See Ground-Start Module, GSM-400
- E4 - See Listen-In Module
- E9 - See Steady Siren
- E10 - See Sweep Siren/Pulsing Bell
- E13 - See Output Relay

Easy-Arm With Key [8] (Location 133)

Programming a "2" into location 133 will permit arming by merely pressing Key [8] momentarily. The complete code will still be required for disarming.

End-of-Line Resistor Supervisory Module, EOLR-8

For high-security installations, install an End-of-Line Resistor Supervisory Module. Without programming, the EOLR-8 can convert the system to up to six non-24-Hour Zones, each of which may contain a combination of normally-open and normally-closed contacts, and each of which is fully supervised by a resistor at the end of the loop. See Input Polarity.

To supervise the wiring to the Panic Buttons when the Panic Zone is wired to an EOLR-8, connect the two white keypad wires to EOLR-8 Terminals E7 and E8 and connect the end-of-line resistor across the white wires *at the keypad*. Do *not* connect the green and white wires together at the keypad as shown on the Wiring Diagram. Refer to the following illustration.

For unsupervised keypad Panic, connect white wires as shown below, or connect one white wire to E7 on the EOLR-8 and splice the other to the green wire at the keypad.

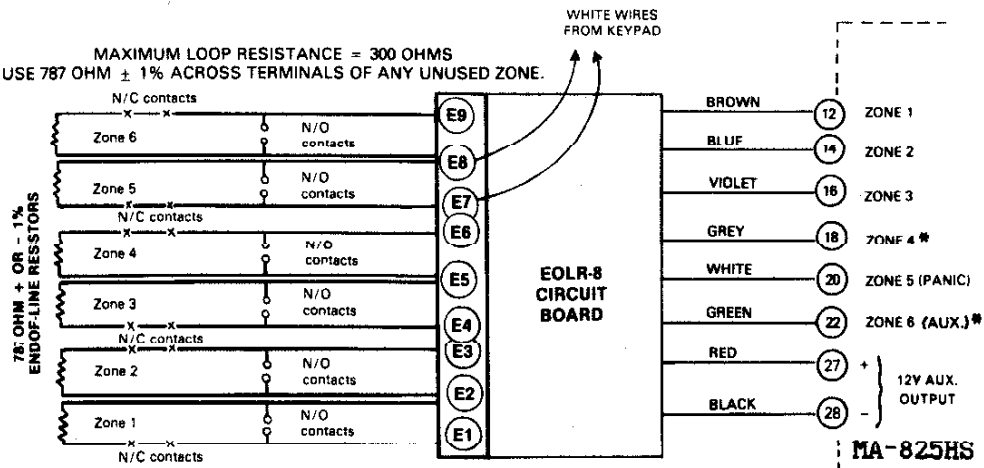

* If using an RP-1003U, (1) do not connect green wire, (2) do not connect gray wire if Zone 4 is used to report Auxiliary trouble.

Exit/Entry Delay (Locations 184-187)

Permits exit and entry through the Exit/Entry Zone (see locations 160, 161) after the system is armed without setting off an immediate alarm. Exit delay allows the user to leave the premises after the control center has been armed. Entry delay allows the user time to enter and disarm the control center. Upon entering, the keypad Mini-Sounder will issue a steady tone to remind the user to disarm the control center.

Exit-Delay time (locations 184, 185) and Entry-Delay time (locations 186, 187) may each be programmed for up to 255 seconds (4-1/4 minutes). See **Time Selection**. If no delay times are programmed, Exit Delay will be 60 seconds; Entry Delay will be 30 seconds. In U.L. installations, exit time may not exceed 60 seconds; entry time may not exceed 30 seconds.

Exit/entry delay may be cancelled by holding down Key [4] until the Mini-Sounder beeps (Instant Alarm), prior to arming. If Key [4] is pressed *after* arming, only entry delay will be cancelled. Exit/entry delay will be restored automatically upon disarming.

Exit/Entry Follower (Locations 162, 163)

A zone that will ignore detection during the exit delay, and only during entry delay if the exit/entry zone is entered first. Thus, detection devices (passive infrared detectors, for example) along the path between the keypad and the exit/entry door will not signal an alarm during exit/entry delay under normal conditions. However, if a device in the Exit/Entry Follower Zone detects a violation when the exit/entry door has not first been entered, there will be no entry delay and the Exit/Entry Follower Zone will go into an instant alarm.

If the control center is armed with the exit/entry delays cancelled (Instant Alarm), any violation on the Exit/Entry Zone or the Exit/Entry Follower Zone will cause an immediate alarm.

Extended Format See Data Format

Fallback Code (Locations 196-199)

After a lengthy power outage (longer than about 4 hours), all user codes may be erased. Should this occur, the system will fail to respond to any personal code, but will respond to the 4-digit Fallback Code that is programmed into PROM locations 196-199 until the personal codes can be restored. The fallback code will only function when all personal codes have been lost. To prevent unidentified entry using the Fallback Code, user codes should be restored as soon as possible.

Ground-Start Module, GSM-400 (Lug E3)

In telephone systems where the dial tone is not continuously active, a Ground-Start Module may be required at Lug E3 to establish the dial tone. For installation, refer to the instructions furnished with the GSM-400 Also see Line-Reversal Module.

Group Shunt (Location 152, 153)

Removal of a preset group of zones from the system. Group shunting is often used to bypass some or all interior zones simultaneously so that the user may move freely about the premises but still be protected from intrusion through armed perimeter zones.

Group shunting is accomplished by pressing Key [S] twice. If the control center is disarmed, all shunted zones will automatically revert back to active (disarmed) zones.

When group shunting is selected, the yellow SHUNT LED on the keypad will light. The zones shunted may be confirmed by holding down Display Shunt Key [S]. When the sounder beeps, the yellow LED will start to flash. The shunted zone(s) may be determined by holding down Key [S] and counting the number of flashes.

Home/Away Switch See Instant/Delay Switch

Input Polarity (Locations 180, 181)

Standard MA-825HS zone polarities are as shown in the Wiring Diagram. To change the polarity of any zone (that is, to change a Normally-Open Zone to Normally-Closed, or vice versa), program entries according to the following table.

Zone-----	1	2	3	4	5	6
Location-----	180	180	180	180	181	181
Entry-----	1	2	4	8	1	2

Instant/Delay Switch (Location 132; Terminals 11 [+] and 28 [-])

The Instant/Delay (or Home/Away) switch performs a function similar to that of Hold-Down Function [4]: when set to Instant (Home) before arming it cancels exit/entry delays. If the switch is set to Instant after arming, only the entry delay will be cancelled. If it is returned to Delay (Away) however, entry delay will be restored. Program a "1" in location 132. Install a single-pole, single-throw switch and cut Jumper F as shown in the Wiring Diagram. With the switch open, the system will be on *Instant*.

NOTE: When this switch is installed and a "1" is programmed in location 132, the ac-failure indication is sacrificed. If Hold-Down Function [4] is used to cancel delay, the ac-failure indication will *not* be lost.

Line-Reversal Module, M-278

The Line-Reversal Module allows the control center to be monitored by a central station through leased lines. On alarm, the module reverses normal line-voltage polarity. For details, refer to the instructions furnished with the module.

Listen-In Module (Lug E4)

If installation requires a Listen-In Module, connect the module to Lug E4. The voltage (12V) at E4 drops to zero when the communicator goes off-hook. When the communicator transmission is completed, the voltage at E4 returns and the Listen-In Module can occupy the phone line. Lug E4 is compatible with Silent Knight Listen-In Module Model 7360 or equivalent.

Loop Response (Locations 176-179)

Loop response is the amount of time, in milliseconds (mS) that a normally-closed circuit must remain open, or a normally-open circuit must remain closed, to trigger an alarm. The slower the loop response, the more immune the system will be to an intermittent circuit activation ("swinger").

Selectable loop-response times are:

7mS (.007 sec.): An extremely fast loop response used primarily for Window Bugs, and to eliminate the need for a pulse extender.

50mS (.05 sec.): Used for momentary Panic Buttons and area-protection devices, such as photoelectric eyes, passive infra-reds, floor mats, etc.

750mS (.75 sec.): The slowest loop-response time, recommended for use with magnetic contacts, window foil, etc. Unless programmed otherwise, loop-response time will be 750mS for all zones.

Low Battery

A low battery alarm will be activated when the battery terminal voltage drops to 11.0V. Low Battery should always be selected for 24-Hour Protection (enter a "4" in location 155), and may be programmed to sound at the Mini-Sounder (enter a "4" in location 175) to alert a user on the premises. A low-battery condition may report to a central station. See Report on Alarm.

Mini-Sounder on Alarm (Location 174, 175)

The Mini-Sounder may be programmed to sound on alarm. This output is untimed; the sounder is reset either by using Reset Key [9] or by disarming.

Opening & Closing Codes See Opening Report; Closing Report

Opening Report (Location 126)

Opening Report After Alarm (Location 131)

Opening and closing reporting are generally used in commercial installations. On disarming, the communicator can transmit an opening code for each user (Opening Report), or it may transmit only when the control center is disarmed after an alarm has occurred (Opening Report After Alarm). Note that Subscriber Identification Numbers (locations 064-067; 092-095) and Opening Codes (locations 038-045) *must* be entered for either opening report.

Select Opening Report (location 126) to report each time the control center is disarmed. Each of up to four users may have his own Opening Code (locations 038-045). If selecting Opening Report, *do not* select Opening Report After Alarm.

Select Opening Report After Alarm ("2" in location 131) to report *only* when disarming after an alarm. This feature may be used by the central station to verify that the subscriber has responded to the alarm and disarmed the control center. If selecting Opening Report After Alarm, *do not* select Opening Report.

Output Relay (Lug E13)

Lug E13 will go to approximately 1Vdc when the relay is tripped. This may be used to activate an externally-connected device. A relay (400 ohms minimum) may be connected to E13 if a diode is inserted in series (cathode to E13, anode to relay).

Panic Zone (Zone 5)

When selecting Zone 5 as a Panic Zone, program Zone 5 for 24-Hour Protection ("1" in location 155) and to Report on Alarm ("1" in location 121). Connect the white keypad wires as shown in the Wiring Diagram. See **End-of-Line Resistor Supervisory Module**.

The Panic Zone is accessed by pressing the two Panic Buttons (keypad Keys [*] and [#]) simultaneously, activating the digital communicator to alert the central station of an emergency. Both buttons must be pressed together. (Also see **Ambush Code**.)

NOTE: Do not program the Panic Zone (Zone 5) for a Restoral Report or a restoral will be sent as soon as the Panic Buttons are released.

Pre-Dial Delay Locations (070, 098)

A Pre-Dial Delay may be used whenever a delay is required before dialing. It is usually required to program Dial-Tone Detection, which causes the communicator to wait for a dial tone before dialing (see Dial-Tone Detection). Certain telephone exchanges send a non-standard dial tone that the communicator may not be able to detect. With these non-standard exchanges, it is possible to program Pre-Dial Delay rather than Dial-Tone Detection. This will cause the communicator to wait for a predetermined period of time before dialing, rather than look for a non-standard dial tone.

Contact the telephone-equipment supplier to find out how long a delay should be required before dialing. Select Pre-Dial Delay by programming one "d" ([8] [PLUS] [5]) for each 4-second delay required. Enter Pre-Dial Delay "d"s starting in location 070 for Telephone 1. If Telephone 2 is used, enter Pre-Dial Delay "d"s starting in location 098.

See Backup Reporting; Double Reporting; Split Reporting. Also see Access Number for Outside Line.

Priority Zone (Locations 146, 147)

A zone that will prevent arming if in trouble. If an attempt is made to arm, the Mini-Sounder will sound continuously and the red LED will not go on. The sounder is silenced by disarming. Any zone may be selected as a Priority Zone. A zone in trouble that is neither a Priority Zone nor an Auto-Shunt Zone will cause an alarm on arming.

Priority Zone with Bypass (Locations 144, 145)

A Priority Zone that will permit arming if the priority condition is bypassed by entering an Arm/Disarm Code, then pressing Reset Key [9]. If the system is so programmed, the zone will auto-shunt, and the condition can be reported to a central station.

Any zone not selected as a Priority Zone may be programmed as a Priority Zone with Bypass. When programming a zone as Priority with Bypass, do not program Remove Auto Shunt.

Pulsing Alarm Output See Alarm Outputs

Receiver Format (Locations 068, 096)

The communicator can be programmed to transmit to any standard central-station receiver. A receiver format must be entered for each telephone number used but a different format may be assigned to each. Refer to Double Reporting and Backup Reporting to determine whether or not Telephone 2 will be programmed. Call

the central station for each telephone number used to confirm the type of receiver in use. Then select the receiver format entry for each telephone number from the following table.

ENTRY	RECEIVER FORMAT	DATA FREQ.	DUTY CYCLE (ON/OFF)	INTERDIGIT TIME
(blank)	Ademco, Silent Knight "slow"	1800Hz	51/49ms	600ms
1	Sasco, Vertex, DCI, Franklin	1800	30/20	600
2	Radionics "fast"	1800	13/12	400
3	Silent Knight "fast"	1800	40/30	560
4	Radionics, DCI, Franklin "slow"	1800	51/49	600
5	Reserved			
6	Ademco "Hi-Speed" (DTMF)			
7	Radionics BFSK			
8	Add "8" for 2300Hz handshake (not for 1800Hz handshake)			

Program the receiver-format entry in location 068 for Telephone 1 and location 096 for Telephone 2, if used.

Ademco Hi-Speed. This format permits high-speed communication to a central station capable of its reception. It has the ability to transmit the status of eight zones on one transmission. The MA-825HS will support the following channel status:

- new alarms
- new restores
- normal (no event since last restore)
- previous event
- opening report
- closing report
- bypass (status report)
- system trouble (low battery)

To select Ademco Hi-Speed format,

1. Program a "6" in the Receiver-Format location(s): 068 (and 096, if used). Do not add "8" for 2300Hz handshake.
2. If Hi-Speed Sum Check is desired, program an "8" in the Data-Format location(s): 069 (and 097, if used).
3. Program Alarm/Restoral and Opening/Closing Subscriber Identification Numbers. For this format, be sure to use all four ID locations, even if the ID number starts with "0".
4. Program other features as usual. Note, however, that programming is not required for Alarm, Restore, or Opening/Closing codes (locations 000-045). This format will automatically assign Zone 1 to channel 1; Zone 2 to channel 2; etc., and User 1 to channel 1; User 2 to channel 2; etc.

Relay Closure on Arming (Location 173)

Program an "8" into location 173 to output 12V dc on Terminals 28 (-) and 29 (+) on arming. If Jumper C is cut, arming will close the isolated contacts across Terminals 29 and 30.

Remove Auto-Shunt (Locations 148, 149)

All zones are preprogrammed for Auto-Shunt, and will be bypassed (automatically shunted out) if in trouble when arming. A momentary beep will sound at the keypad to warn that the system has been armed without the protection of the auto-shunted zone. (Note that the exit/entry door must be closed before arming, otherwise the Exit/Entry Zone will be auto-shunted.) Auto-shunting may be removed from any zone by programming.

NOTE: If auto-shunt is removed from a zone in trouble that is not programmed for Priority arming (locations 146, 147), that zone will cause an alarm on arming. If selecting Priority With Bypass, *do not* select Remove Auto-Shunt.

For U.L. installations, non-24-Hour Zones *with* auto-shunt (Remove Auto-Shunt *not* programmed) must be programmed for Priority Zone with Bypass. If an attempt is made to arm with these zones in trouble, the Mini-Sounder will come on, "0" will be displayed, and the panel will not arm (enter the arm/disarm code to silence the sounder and clear the display). To arm, hold down Reset Key [9] for about 2 seconds, then enter the arm/disarm code.

Report on Alarm (Locations 120, 121)

Violation of a zone selected to Report on Alarm will cause the communicator to transmit the code selected for that zone to the central station. Enter Alarm Codes (locations 000-013) for each zone to report on alarm, even if identical codes are used for different zones.

Restoral Report

Control-Center Restoral (Locations 122, 123)

Zone Restoral (Locations 140, 141)

NOTE:

1. If programming Zone Restoral, Control-Center Restoral must be programmed as well.
2. When selecting a Restoral Report, (a) Subscriber Alarm/Restoral Identification Numbers must be programmed for Telephone 1 (locations 060-063) and Telephone 2 (locations 088-090), if used; and (b) Restore Codes (locations 024-037) must be entered for each zone selected to report a restoral.
3. When selecting Zone 5 as a Panic Zone, do not program it for a

Restoral Report, otherwise a restoral will be sent as soon as the Panic Buttons are released.

The communicator can transmit a report to the central station when a zone or the control center is restored. To select the time of reporting, refer to the following table.

PROGRAM:	FOR CONTROL-CENTER RESTORAL REPORT TO BE SENT:	AND FOR ZONE RESTORAL REPORT TO BE SENT:	
Instant Auto-Reset (locations 156, 157)	* When zone is repaired, or * When control-center is disarmed	* When zone is repaired, whether control-center is armed or disarmed	
Auto-Reset After Alarm Time-Out (locations 156, 157; "2" in location 132)	* When resets (alarm times out & zone is repaired), or * When control center is disarmed	* When zone resets (alarm times out & zone is repaired, whether control center is armed or disarmed)	
X	X	(See Note 2) ZONE REPAIRED WITH CONTROL CENTER	
No Auto-Reset	* When control center is disarmed (regardless of zone condition)	ARMED * When control center is disarmed	DISARMED * When control center is armed & disarmed again
NOTE: 1. 24-Hour Zone restorals are sent as shown under ZONE RESTORAL. 2. Suggestion: Program Zone-Restoral or 24-Hour Zones with Auto-Reset or Priority to prevent accidental auto-shunting of a latched zone. See Abort Delay Before Dialing.			

Restore Codes See Restoral Report.

Selective Shunt (Locations 150, 151)

Removal of one particular zone from the system. Any or all zones programmed for selective shunt may be removed from the system, but each must be removed separately (see Group Shunt).

Selective shunting is accomplished by pressing Shunt Key [S] followed by the zone number. If the control center is disarmed, all shunted zones automatically revert back to active (disarmed) zones.

When one or more zones are shunted, the yellow SHUNT LED on the keypad will light. The zones shunted may be confirmed by holding down Display Shunt Key [S] until it beeps; this will cause the yellow LED to flash. Count the number of flashes to determine the zone(s) shunted.

See Conditional Closing and Conditional Report on Manual Shunt.

Single-Digit Format See Data Format

Split Reporting (Location 131; 232, 233)

Split Reporting ("1" in location 131) causes alarms on Zones 1-6 and Low Battery to report to one telephone number, and Openings and Closings to report to a second telephone number.

Split Reporting is selectable by zone (locations 232, 233*). Program the zones to report to *Telephone Number 2* as follows. Note that an "8" (Opening/Closing) is preprogrammed into location 233.

***NOTE:** Zone locations 232 and 233 are contained on PROM Page 1 (see **PROGRAMMING STEPS**) and thus not shown on the Programming Record Sheet. To program data entries into these locations, set the PAGE switch on the PRO-410/410M Programmer to [1]. (Note the **CAUTION** after Programming Step 3 at the beginning of this section.)

Zone-----	1	2	3	4	5	6	LOW	OPN
Location-----	232	232	232	232	233	233	BAT	CLO
Entry-----	1	2	4	8	1	2	4	8

If Split Reporting is selected, enter Subscriber Identification Numbers for Telephone 2 (locations 088-095) and other information required for Telephone 2 (locations 096-115).

NOTE: Subscriber Identification Numbers for both Telephones 1 and 2 *must* be entered, even if they are the same.

Steady Siren (Lug E9)

Lug E9 will go to approximately 1Vdc when activated. This may be used to trip an externally-connected device. A relay (400 ohms minimum) may be connected to Lug E9 if a diode is inserted in series (cathode to E9, anode to relay).

Subscriber Identification Numbers (Locations 060-067; 088-095)

Different Subscriber Identification Numbers may be used by the central station to distinguish Alarm and Restoral Reports (locations 060-063) from Opening and Closing Reports (locations 064-067). Both identification numbers *must* be programmed, even if they are the same. See **Report On Alarm; Restoral Reports; Opening Reports; Closing Reports.**

Furthermore, if a second telephone is used, different Subscriber Identification Numbers may be required for Alarm/Restoral Reports (locations 088-091) and Opening/Closing Reports (locations 092-

095). As above, both identification numbers must be programmed, even if they are the same. See **Double Reporting; Backup Reporting**.

NOTE:

1. If the central station cannot accept two-digit or extended event codes, the Alarm and Restore Codes may be the same as the Opening and Closing Codes if the respective Subscriber Identification Number is different.
2. Enter at least 3 digits for each Subscriber Identification Number, even if the first two are zeros. The fourth digit is available for those receivers capable of recognizing 4-digit subscriber codes.

Sum Check See Data Format

Sweep Siren/Pulsing Bell (Lug E10)

Lug E10 will go to approximately 1Vdc when activated. This may be used to trip an externally-connected device. A relay (400 ohms minimum) may be connected to E10 if a diode is inserted in series (cathode to E10, anode to relay).

Swinger Shutdown (Locations 158, 159)

To prevent "swingers" (intermittents) from causing repeated false alarms, any zone (including Low Battery) may be programmed for Swinger Shutdown. Any zone so programmed must also be programmed for Auto-Reset. This will cause the zone to reset only twice (3 alarms) until rearmed. See **Auto-Reset**.

Telephone Numbers (Locations 073-087; 101-115)

To report to a central station, Telephone Number 1 (locations 073-087) *must* be programmed. Telephone Number 2 (locations 101-115) is programmed if Backup Reporting or Double Reporting is selected.

Telephone Number 1 will be preceded by at least one Dial-Tone Detection entry ("E" in location 072) or Pre-Dial Delay entry ("d" in location 070) to ensure that the communicator detects a dial tone or waits a reasonable time to access a telephone line before dialing. (See **Dial-Tone Detection; Pre-Dial Delay**.) Furthermore, private telephone systems may require a separate Dial-Tone Detection or Pre-Dial Delay digit, followed by an Access Number (location 071) to obtain an outside line. (See **Access**

Number for Outside Line.)

It should be noted here that Telephone Number 1 need not actually start in location 079 nor end in location 087, as extra locations have been provided to allow for additional prefix digits, if required. What is important is that Telephone Number 1, with its associated Pre-Dial Delay, Access Number, and Dial-Tone Detection, be wholly contained within locations 070-087, and that they be in their proper sequence. It may, in fact, be advantageous to leave two or three blank locations before entering the telephone number to allow for the unexpected (an additional Pre-Dial Delay, for example).

The extra locations within the telephone number group may also be used to correct telephone-number programming errors. To correct an error, enter an "F" ([8] [PLUS] [7]) in the location with the incorrect digit and enter the correct digit in the following location. The "F" will be ignored by the communicator when dialing.

The above is true for Telephone Number 2 (locations 101-115) as well.

NOTE: The symbol "*" in a phone number represent the number 10; "#" represents the number 11.

Time-Out See Alarm Time-Out, Time Selection

Time Selection (Also see Programming Sheet)

The following times are programmable:

Time	Locations	Units	Max. Programmable Time
Abort Delay	182, 183	seconds	4 min, 15 sec (255 sec)
Exit Delay	184, 185	seconds	4 min, 15 sec (255 sec)
Entry Delay	186, 187	seconds	4 min, 15 sec (255 sec)
Sweep Siren	188, 189	minutes	4 hr, 15 min (255 min)
Pulsing Bell	188, 189	minutes	4 hr, 15 min (255 min)
Steady Siren	190, 191	minutes	See note below*
Alarm Output 2 Relay	192, 193	minutes	See note below*
Door-Chime Duration	200, 201	1/4 seconds	See note below*

*When both locations are left blank, the feature will remain active until the system is disarmed. When both locations are programmed "F", the output will time out after 4 hours, 15 minutes (255 minutes); the Door Chime will time out after 63.75 seconds (255 quarter seconds).
NOTE: In the State of California, do not program a time-out for fire alarms.

The Time Selector Chart on the Programming Sheet shows example times only, in seconds or minutes. In reality, any time up to those shown in the foregoing table may be programmed. Note that each of the above times is programmed in two locations. The

first location has a time factor of 1; the second a time factor of 16.

1st BOX	2nd BOX
tx1	tx16

Time (t):	0	1	2	3	4	5	6	7	8	9	10	11	12	13	14	15
Entry:	*	1	2	3	4	5	6	7	8	9	0	b	C	d	E	F

* Blank. **NOTE:** With both programming locations blank, the Output-2 Relay, Steady Siren and Door-Chime will remain active until disarmed; the Sweep Siren and Pulsing Bell will not activate. For Door Chime and Output-2 Relay, programming a single unit of time (i.e., 1 quarter-second or 1 minute) will cause *no output*. (This may be useful in installations *not* using Door Chime, to prevent accidental activation.)

To select a time up to 15 seconds, 15 minutes, or 15 quarter-seconds (3.75 seconds), program the respective entry into the first box only; do not program the second box. To select a time greater than 15 seconds, 15 minutes, or 15 quarter-seconds, program both boxes as follows:

1. For the feature selected, choose an appropriate time in basic units (all seconds, minutes, or quarter-seconds -- not minutes and seconds, etc.).
2. Divide the time chosen by 16. Enter the *quotient* in the 2nd BOX and the *remainder* in the 1st BOX.
3. Check entries by adding the contents of the 1st BOX to 16 times the contents of the 2nd BOX. (Remember that a "zero" entry represents "10".)

Example 1. Program an Entry Delay of 1-1/2 minutes.

1. Entry Delay time (locations 186, 187) is in units of seconds, thus delay time is 90 seconds.
2. Divide by 16: $90/16 = 5$ (quotient) + 10 (remainder). Enter the quotient in the 2nd BOX and the remainder in the 1st BOX:

186	187
0	5

remainder quotient
(0 for "10")

3. Check entries (remember, a "0" entry = "10"): $10 + 16(5) = 90$.

Example 2. Program the Mini-Sounder to sound a Door "Chime" for 4 seconds.

1. Chime-Time duration (locations 200, 201) is in units of quarter-seconds, thus chime duration is 16 quarter-seconds.
2. Divide by 16: $16/16 = 1$ (quotient) + 0 (remainder). Enter the quotient in the 2nd BOX and the remainder (blank entry for "0") in the 1st BOX:

200	201
	1

remainder quotient
(blank for "0")

3. Check entries (remember, a blank entry = "0"): $0 + 16(1) = 16$.

Timed Alarm Output See Alarm Outputs

Touch-Tone Dialing (Location 130)

Touch-Tone/Rotary Backup (Location 130)

Select Touch-Tone Dialing only when the subscriber has Touch-Tone service. Touch-Tone dialing is faster than rotary dialing, but not always as reliable.

For the communicator to use Touch-Tone on all dial attempts, add a "1" to location 130. To use Touch-Tone on the first attempt with subsequent Rotary dial attempts, add a "2" to location 130. Touch-Tone Dialing will override Touch-Tone Rotary Backup if both are selected. Note that if Backup Reporting is also selected, the communicator will use Rotary dial to reach Telephone 2.

Trouble

An abnormal zone condition (a short on a normally-open zone, or a break on a normally-closed zone) when disarmed that will generally cause a visible or audible indication at the keypad. A trouble condition occurring on an armed zone will cause an alarm.

Two-Digit Format See Data Format

Zone Restoral See Restoral Report

Zone 6 "Fire" with BFSK (Location 132)

To have the central-station receiver print "FIRE" when receiving an alarm on Zone 6 (using BFSK format), enter a "4" in location 132. With no Alarm Code programmed, the receiver will print only

"FIRE". If an Alarm Code is used ("1", for example), the receiver will print the Alarm Code as well ("ALARM FIRE 1"). If this feature will not be utilized, enter an Alarm Code on Zone 6 if reporting.

24-Hour Protection (Locations 154, 155)

A zone that provides protection at all times, whether or not the system is armed.

Neither the green STATUS nor the red ARMED/MEMORY LED will indicate the condition of a zone programmed for 24-Hour Protection, however an alarm condition will be recorded by Alarm History. See Hold-Down Function [2].

FOR SALES, SERVICE, OR TECHNICAL HELP, CALL TOLL FREE:

(800) 645-9445

CHANGES FROM THE PREVIOUS EDITION

Summarized below are changes made to this manual since the last edition.

- Page 5: SPECIFICATIONS revised (metric added).
- Page 6: Recommended U.L.-Listed Devices, Ademco Bell numbers corrected.
- Page 8: Key [4], Instant Protection text revised.
- Page 29: Priority Zone with Bypass text revised.
- Page 42: Warranty revised.
- Page 45: INDEX corrected (Wiring Diagram).
- Page 46: WIRING DIAGRAM revised (Back-Lit Keypad Terminal 28 changed to Terminal 34).

5. INSTALLATION

CONTROL-CENTER MOUNTING

Choose a location near (a) a continuously-powered ac source (do not connect to a switched outlet), (b) a cold-water-pipe ground, ideally no further away than 10 feet, and (c) telephone lines (keep telephone wiring away from speaker wires). Remove appropriate knockouts for cables. Place the control center at a convenient viewing height and mark the mounting holes.

If a keypad or keyswitch is to be mounted at the control panel, remove the knockout on the enclosure door (see **KEYPAD MOUNTING**). Backplate mounting is available for remote RP-1003H Keypads; junction-box mounting is available for remote RP-1003H Keypads and RP1003L Keyswitch Stations. See **ORDERING INFORMATION** (Section 1).

NOTE: If installing an RP-1003U Fire Supervision and Indicator Station in a U.L. installation, it must be mounted in the knockout in the control-center door.

GROUNDING

Connect the control-center grounding screw to a metal cold-water pipe. Do not use a gas pipe, plastic pipe or ac ground connections. Use at least 16 gauge wire. Make the run as short and direct as possible, without any sharp bends in the wire.

TAMPER SWITCHES

Tamper switches may be installed to prevent opening of the enclosure door or removal of the enclosure from the wall. Ideally, tamper switches should be connected to a zone that is active at all times, thus it may be necessary to program that zone for 24-Hour Protection. When used on a normally-open zone, normally-closed tamper switches should be wired in parallel. On a normally-closed zone, install NAPCO TPS-2 normally-open tamper switches (normally-closed when set) in series.

There are two places in the cabinet to mount tamper switches. To prevent cabinet removal from the wall, there are three mounting holes on the left side of the cabinet, and another on the back that allows the tamper-switch button to contact the wall. To prevent opening the cabinet door, there are three mounting holes on the right side of the cabinet. When mounted, the tamper-switch button should contact the inside of the door.

NOTE: Alert the user that opening the control-center door (for access to the ARM-DISARM/RUN/LOAD switch when changing codes, for example) will cause a tamper alarm.

KEYPAD MOUNTING

Raise the hinged front panel to gain easy access to the mounting holes, then proceed as follows.

Mounting onto an Enclosure Door.

Use screwdriver to remove knock-out in front door. Align holes in keypad with slots in door and secure with #6 screws and nuts. Lower front panel.

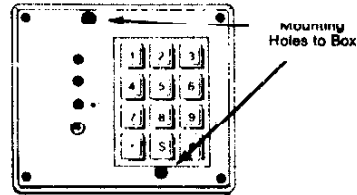

Surface Mounting onto a Wall Using the RPB-1.

Mount RPB-1 onto wall using #6 pan head screws. Pull wires through hole in back or run cable through smaller hole in side. Using a cable tie, secure wires to strain-relief bracket (see illustration).

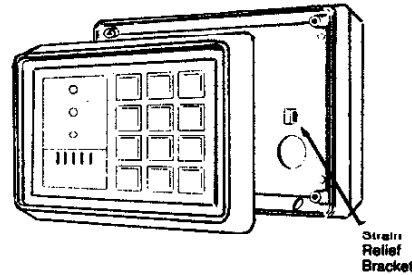

Shorten keypad wires as needed to fit into RPB-1. Mount keypad onto RPB-1 with screws provided. Lower front panel.

Recessed Mounting into a Wall Using the RPB-2.

Hold mounting box flush against wall (mounting ears towards wall) and mark around outside of box. Cut out hole carefully, insert box and tighten box mounting screws. Place keypad on box. Use #6 screws through mounting holes to secure keypad to box. Lower front panel.

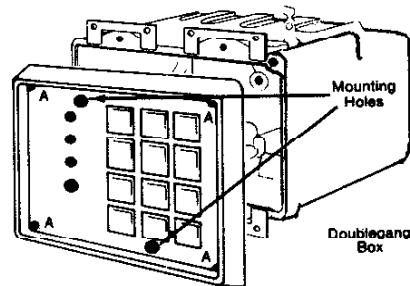

NOTE: Four corner holes ("A") may be used for recessed mounting directly into a wall. Use the Mounting Template (next page) as a marking/cutting guide.

After the keypad is mounted, peel off the clear vinyl covering protecting the front panel.

KEYPAD MOUNTING TEMPLATE

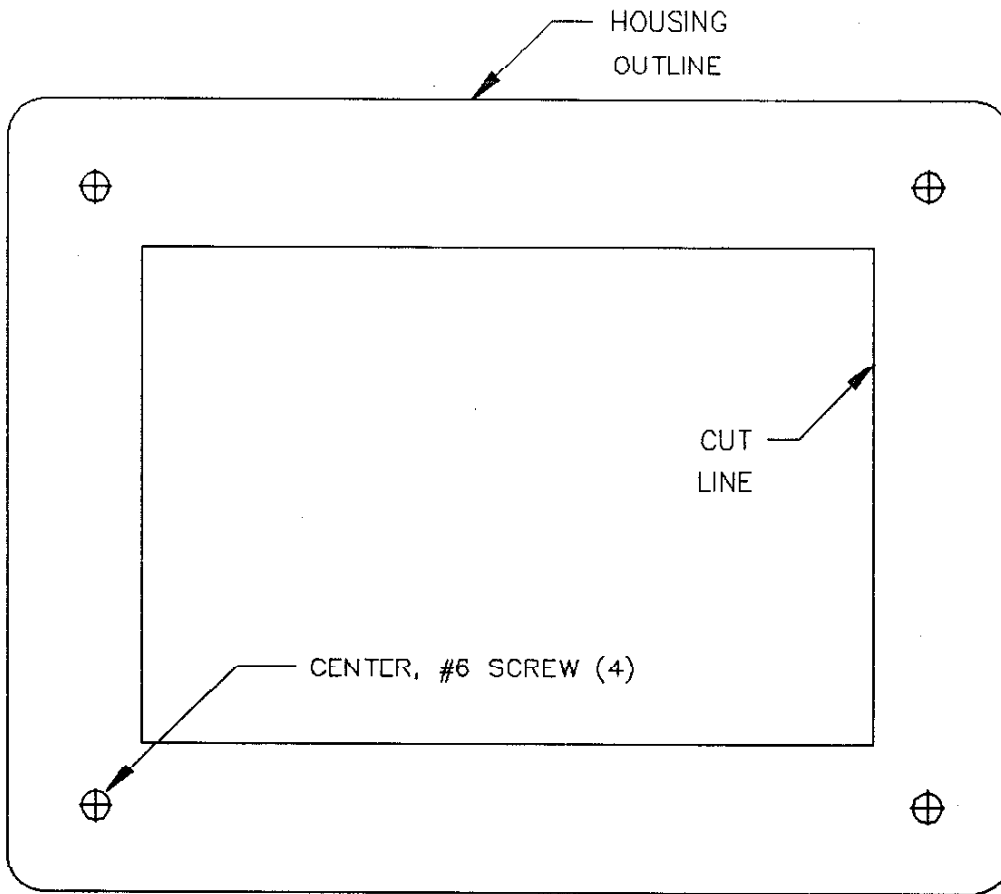

TESTING THE SYSTEM

Check system operation after installation. Call the central station to advise them of a test. Initiate an alarm, preferably on a zone that activates a steady siren. Confirm proper signaling, then call the central station to verify communication.

SELECTING FEATURES AND WIRING OPTIONS

List programmed PROM features on the Installation Record Label and affix the label inside the cabinet door. After wiring and testing are completed, fill in the balance of the Installation Record Label for future reference, then date and sign at the top.

NAPCO LIMITED WARRANTY

NAPCO SECURITY SYSTEMS, INC. (NAPCO) warrants its products to be free from manufacturing defects in materials and workmanship for fifteen months following the date of manufacture. NAPCO will, within said period, at its option, repair or replace any product failing to operate correctly without charge to the original purchaser or user.

This warranty shall not apply to any equipment, or any part thereof, which has been repaired by others, improperly installed, improperly used, abused, altered, damaged, subjected to acts of God, or on which any serial numbers have been altered, defaced or removed. Seller will not be responsible for any dismantling or reinstallation charges.

In case of defect, contact the security professional who installed and maintains your security system. NAPCO shall have no obligation under this warranty, or otherwise, if the product has been repaired by others, improperly installed, improperly used, abused, altered, damaged, subjected to accident, nuisance, flood, fire or acts of God, or on which any serial numbers have been altered, defaced or removed. NAPCO will not be responsible for any dismantling, reassembly or reinstallation charges.

In order to exercise the warranty, the product must be returned by the user or purchaser, shipping costs prepaid and insured to NAPCO. After repair or replacement, NAPCO assumes the cost of returning products under warranty.

There are no warranties, express or implied, which extend beyond the description on the face hereof. There is no express or implied warranty of merchantability or a warranty of fitness for a particular purpose. Additionally, this warranty is in lieu of all other obligations or liabilities on the part of NAPCO.

Any action for breach of warranty, including but not limited to any implied warranty of merchantability, must be brought within the six months following the end of the warranty period. In no case shall NAPCO be liable to anyone for any consequential or incidental damages for breach of this or any other warranty, express or implied, even if the loss or damage is caused by the seller's own negligence or fault.

This warranty contains the entire warranty. It is the sole warranty and any prior agreements or representations, whether oral or written, are either merged herein or are expressly cancelled. NAPCO neither assumes, nor authorizes any other person purporting to act on its behalf to modify, to change, or to assume for it, any other warranty or liability concerning its products.

In no event shall NAPCO be liable for an amount in excess of NAPCO's original selling price of the product, for any loss

or damage, whether direct, indirect, incidental, consequential, or otherwise arising out of any failure of the product. Seller's warranty, as hereinabove set forth, shall not be enlarged, diminished or affected by and no obligation or liability shall arise or grow out of Seller's rendering of technical advice or service in connection with Buyer's order of the goods furnished hereunder.

NAPCO RECOMMENDS THAT THE ENTIRE SYSTEM BE COMPLETELY TESTED WEEKLY.

Warning: Despite frequent testing, and due to, but not limited to, any or all of the following; criminal tampering, electrical or communications disruption, it is possible for the system to fail to perform as expected. NAPCO does not represent that the product/system may not be compromised or circumvented; or that the product or system will prevent any personal injury or property loss by burglary, robbery, fire or otherwise; nor that the product or system will in all cases provide adequate warning or protection. A properly installed and maintained alarm may only reduce risk of burglary, robbery, fire or otherwise but it is not insurance or a guarantee that these events will not occur. **CONSEQUENTLY, SELLER SHALL HAVE NO LIABILITY FOR ANY PERSONAL INJURY, PROPERTY DAMAGE, OR OTHER LOSS BASED ON A CLAIM THE PRODUCT FAILED TO GIVE WARNING.** Therefore, the installer should in turn advise the consumer to take any and all precautions for his or her safety including, but not limited to, fleeing the premises and calling police or fire department, in order to mitigate the possibilities of harm and/or damage.

NAPCO is not an insurer of either the property or safety of the user's family or employees, and limits its liability for any loss or damage including incidental or consequential damages to NAPCO's original selling price of the product regardless of the cause of such loss or damage. If the user wishes to protect itself to a greater extent, NAPCO will, at user's sole cost and expense, obtain an insurance policy to protect the user, supplemental to user's own policy, at a premium to be determined by NAPCO's insurer upon written notice from user by Certified Mail, Return Receipt Requested, to NAPCO's home office address, and upon payment of the annual premium cost by user.

Some states do not allow limitations on how long an implied Warranty lasts or do not allow the exclusion or limitation of incidental or consequential damages, or differentiate in their treatment of limitations of liability for ordinary or gross negligence, so the above limitations or exclusions may not apply to you. This Warranty gives you specific legal rights and you may also have other rights which vary from state to state.

NOTE: If the non-replaceable pigtail fuse (not shown) is blown, return the board to NAPCO for repair. (This fuse is not serviceable in the field.)

WIRING LEGEND

INSTRUCTIONS: Should removal of the circuit board be necessary, use this wiring legend to relocate leads to their respective terminals. Enter wire identification number or color code in WIRE NUMBER column; wire function in DESCRIPTION column (optional).

TERMINAL NUMBER	WIRE NUMBER	DESCRIPTION
1		
2		
3		
4		
5		
6		
7		
8		
9		
10		
11		
12		
13		
14		
15		
16		
17		
18		
19		
20		
21		
22		
23		
24		
25		
26		
27		
28		
29		
30		
31		
32		
33		
34		

NOTES:

INDEX

Abort Delay	16	Double Reporting	2
Ac Failure Indication	7, 9	"E" Lugs	2
Also see Instant/Delay Switch	25	Easy Arm	2
Access Number for Outside Line	16	End-of-Line Resistor Module EOLR-8	2
Ademco Hi-Speed Format	30	Entry Delay Time	2
Alarm Codes, see Report on Alarm	31	Also see Time Selection	35-37
Alarm History (Key [2])	8, 17	Exit Delay Time	2
Alarm Outputs	17	Also see Time Selection	35-37
Alarm Time-Out	17	Exit/Entry Follower	2
Also see Time Selection	35-37	Extended Format	20-2
Ambush Code	11, 17	Fallback Code	11, 2
Ambush Zone	11, 17	Features	3-
Anti-Jam Time	18	Fire Zone 6 with BFSK	3
Arm/Disarm (Personal) Codes	10	Formats, see	
Arm-Disarm/Run/Load Switch	9, 10-11	Data Format	20-2
Armed/Memory LED	7, 8	Receiver Format	29-3
Arming/Disarming	9, 11	Glossary	12, 16-3
Arming Without Ac	7	Ground-Start Module (GSM-400)	2
Audible Test on Arming, see Test	8	Grounding	3
Auto-Reset	18	Group Shunt	2
Auto-Reset After Alarm Time-Out	19	Home/Away Switch,	
Auto-Shunt Zone,		see Instant/Delay Switch	2
see Remove Auto-Shunt	31	Hold-Down Functions	8-
b-F; 10-15, (How to Program)	13	Input Polarity	2
Backup Reporting	19	Installation	3
Battery	10, 19	Installation Record	13, 4
Burglary Output Time-Out	17	Instant/Delay Switch	2
Also see Time Selection	35-37	Instant Protection (Key [4])	
Closing Codes	19-20, 22	Jumpers,	
Closing Report	19-20, 22	A, see ARM-DISARM/RUN/LOAD Switch	
Come Up Armed After Power Failure	20	C, see Alarm Outputs	17, 3
Communicator Format, see		D, see Alarm Outputs	17
Receiver Format	29-30	E, see Alarm Outputs	17
Conditional Closing Report	19-20, 22	F, see Instant/Delay Switch	20
Conditional Closing/ Status Report	19-20, 22	Keypad,	
Conditional Opening Report, see		Controls & Indicators	7-9
Opening Report After Alarm	22, 28	Functions	2, 7, 1
Conditional Report on Manual Shunt	20	Mounting	40
Control-Center Restoral	22, 31-32	Panic Wiring	24
Data Format	20-22	Line-Reversal Module (M278)	25
Day Zone	22	Listen-In Module	25
Dial Delay, see Pre-Dial Delay	29	Loop Response	25
Also see Telephone Numbers	34	Low Battery	25
Dial-Tone Detection	23	Mini-Sounder Indications	4, 6
Also see Telephone Numbers	34		
Disable Bell Test	23		
Display Shunt	9		
Door Chime (Key [5])	8, 23		
Also see Time Selection	35-37		

Also see Day Zone	22-23	Group	26
Anti-Sounder on Alarm	27	Key [S]	7, 9
Arming, see		LED	7
Control-Center	39	Selective	32
Keypad	40	Single-Digit Event Code Format	21
1-Button Arming, see		Speaker/Bell Output	17
Easy Arm	24	Specifications	5
Arming Codes	28	Split Reporting	33
Arming Report	22, 28	Status, see	
Arming Report After Alarm	22, 28	Key [3]	8
Arms	10	LED	7, 8
Arming Information	6	Also see Day Zone	22-23
Alarm Relay (Lug E13)	28	Steady Siren (Lug E9)	17, 33
Alarm Outputs, see Alarm Outputs	17	Subscriber Identification Number	33-34
		Subscriber PROM	2, 12-13
		Also see Anti-Jam Time	18
		Split Reporting	33
Alarm	7, 11	Sum Check Format	22
Alarm Zone	11, 24, 28	Sweep Siren (Lug E10)	17, 34
Personal Codes	9, 10-11	Swinger Shutdown	34
Arms-Up Sequence	10		
Arms-Dial Delay	29	Tamper Switches	39
Also see Dial-Tone Detection	23	Telephone Cord	10
Telephone Numbers	34	Telephone Numbers	34-35
Priority Zone	29	Test (Key [1])	8
Priority Zone with Bypass	29	Time-Out, see Alarm Time-Out	17
Programming, see		Also see Time Selection	35-37
Materials	12	Time Selection	35-37
Record Sheets	12, 14-15	Timed Alarm Output, see Alarm Outputs	17
Steps	12-13	Touch-Tone Dialing	37
Using Bell (Lug E10)	17, 34	Two-Digit Event Code Format	21-22
Receiver Format	29, 30	U.L.-Listed Devices	6
Delay Closure on Arming	31	Wiring Diagram	46
Move Auto-Shunt	31		
Port on Alarm	31	Zone 6 "Fire" with BFSK	37
Reset, Key [9]	9	Zone Restoral Report	22, 31
Also see Door Chime	23		
Day Zone	22-23	1-Button Arming, see Easy Arm	24
Restoral Report	22, 31	2-Digit Event Code Format	21-22
Store Codes	22, 31	24-Hour Protection	38
11X Telephone Jack	10		
Selective Shunt	32		
Shunt, see			

WIRING DIAGRAM

MAGNUM ALERT 825HS

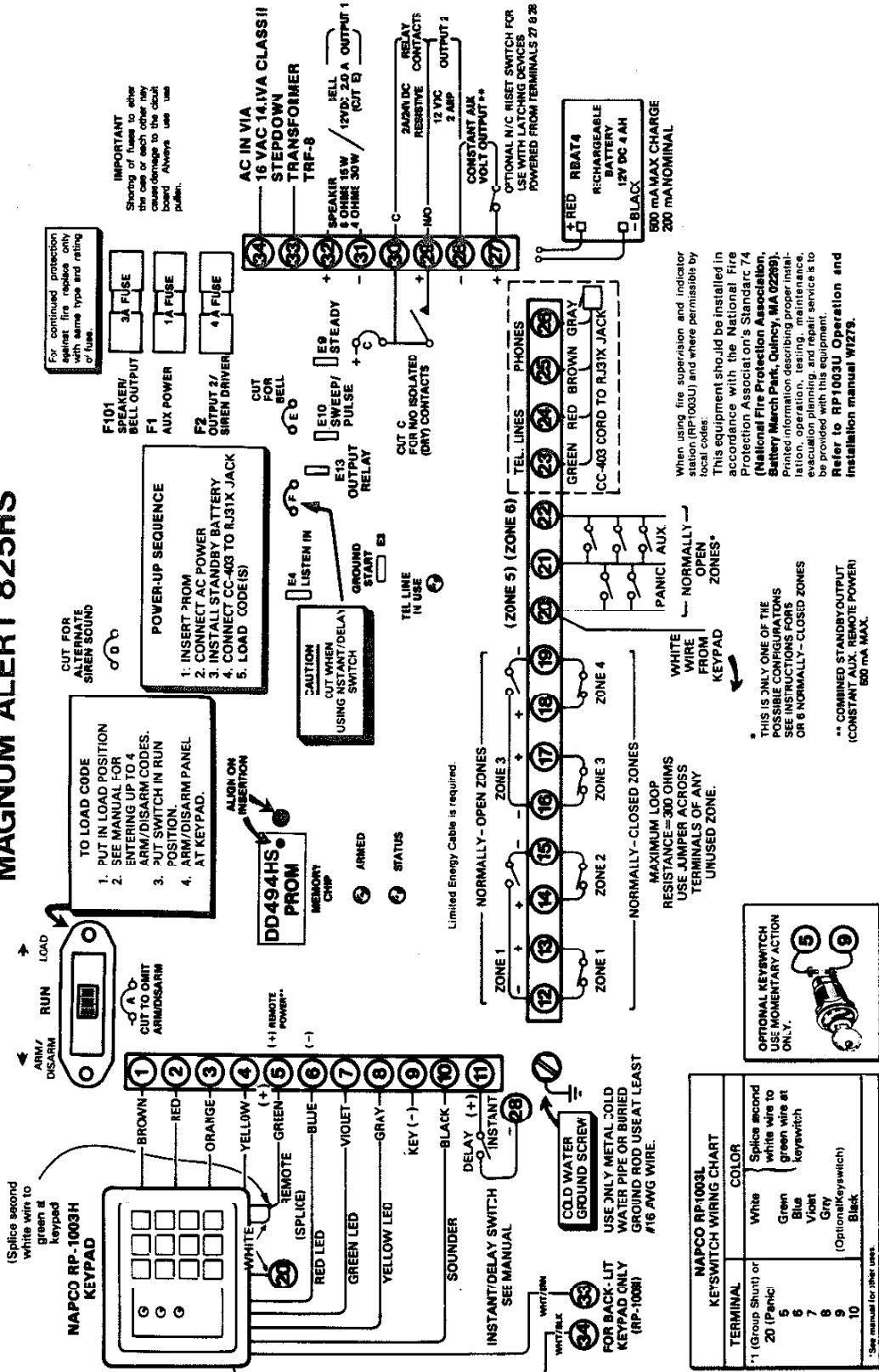



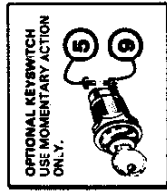

NAPCO RP1003L KEYSWITCH WIRING CHART	
TERMINAL	COLOR
*1 (Group Shunt) or 20 (Panic)	White
5	Splice second white wire to green wire at keypad
6	Green
7	Blue
8	Violet
9	Gray
10	Black (Optional keyswitch)

*See manual for other uses.

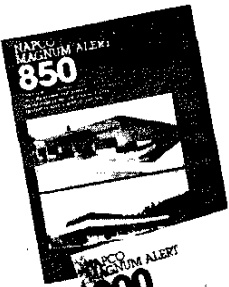

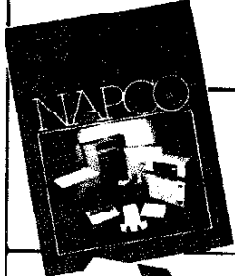
Sales aids prepared by Napco help you move more products and earn more profits. Order now to start putting this carefully researched material to work for you. Fill out this order form (both sides) and mail it with your check or money order payable to Napco. Or call Napco today for the name of your nearest stocking distributor. (See reverse side for toll-free numbers and address.)

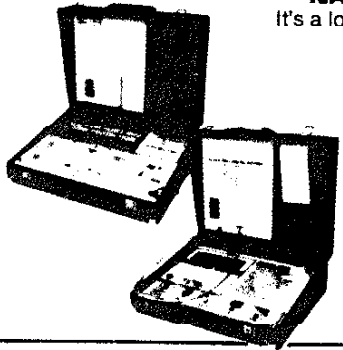
		QUANTITY	AMOUNT
    	<p>NAPCO CUSTOMER LITERATURE Full-color folders in easily understandable language. Show how each system protects the customer's home or business. Ideal for sales presentations, mailers, etc. Priced \$0.00 per 100 (Sold in lots of 100)</p> <p>Magnum Alert-700 Security System (A177) <input type="checkbox"/></p> <p>Magnum Alert-800 Security System (A166) <input type="checkbox"/></p> <p>Magnum Alert-825 Security System Residential (A218) <input type="checkbox"/></p> <p>Commercial (A218 COM) <input type="checkbox"/></p> <p>Magnum Alert-850 Security System Residential (A221) <input type="checkbox"/></p> <p>Commercial (A221 COM) <input type="checkbox"/></p> <p>in French, Residential (A239) <input type="checkbox"/></p> <p>in French, Commercial (A239 COM) <input type="checkbox"/></p> <p>Magnum Alert-854 Security System Residential (A245) <input type="checkbox"/></p> <p>Commercial (A245 COM) <input type="checkbox"/></p> <p>Magnum Alert-900 Security System Residential (A191) <input type="checkbox"/></p> <p>Commercial (A191 COM) <input type="checkbox"/></p> <p>Shock Guard (A186) <input type="checkbox"/></p>		
	<p>NAPCO PROPOSAL FOLDER Pocketed folder for literature, technical sheets and proposals. Helps you wrap up sales with a professional look. Literature Folder (A176) .75 each <input type="checkbox"/></p>		
	<p>NAPCO SALES & TECHNICAL GUIDE Binder contains. Sales literature; Working instructions for all products; Engineering updates and Memos; Troubleshooting guides. You are placed on a select mailing list to receive all future updates. Binder (A173) \$24.95 each <input type="checkbox"/></p>		
	<p>NAPCO BRIEFCASE DEMONSTRATORS It's a lot easier to close sales by demonstrating the system right at your customer's premises.</p> <p>Magnum Alert-800 Demonstrator Case (SDC/800) \$299.95 each <input type="checkbox"/></p> <p>Magnum Alert-825 Demonstrator Case (SDC/825) \$299.95 each <input type="checkbox"/></p> <p>Magnum Alert-850 Demonstrator Case (SDC.850A) \$249.95 each <input type="checkbox"/> (Add \$2.50 for freight)</p>		
	TOTAL		

I'd like to preview your Consumer Literature first. Please send a free copy of the item(s) checked below:

- | | |
|--|---|
| <input type="checkbox"/> Magnum Alert-700 Security System | <input type="checkbox"/> Magnum Alert-854 Security System |
| <input type="checkbox"/> Magnum Alert-800 Security System | <input type="checkbox"/> Magnum Alert-900 Security System |
| <input type="checkbox"/> Magnum Alert-825 Security System | <input type="checkbox"/> Shock Guard |
| <input type="checkbox"/> Magnum Alert-850 Security System | <input type="checkbox"/> Napco Proposal Folder |
| <input type="checkbox"/> Magnum Alert-850 Security System (French) | |

Enclosed is my check/money order for \$ _____ to cover the Napco sales aids ordered on the reverse side.

NAME _____

TITLE _____

COMPANY _____

ADDRESS _____

CITY _____ STATE _____ ZIP _____

TELEPHONE _____



SALES DEPARTMENT
NAPCO SECURITY SYSTEMS, INC.
333 Bayview Avenue, Amityville, NY 11701
(800) 645-9445 (USA) (800) 832-5688 (NY) (800) 247-4047 (CAN) Telex 510-227-988

PLACI
STAM
HERE

SALES DEPARTMENT
NAPCO SECURITY SYSTEMS, INC.
333 Bayview Avenue
Amityville, New York 11701

**SEND NOW FOR
YOUR NAPCO
BUSINESS
BUILDERS.**

D.R.